



# SERVICE MANUAL

VHF REPEATER

# IC-RP1620

---

---

---

---

---

## INTRODUCTION

This service manual describes the latest service information for the **IC-RP1620** VHF REPEATER at the time of publication and covers the following versions:

VERSION NO.	VERSION	SYMBOL
#01*1, #11*2	U.S.A.	USA-W
#02*1, #12*2	Italy	ITA-W
#03*1, #13*2	Europe	EUR-W
#04*1, #14*2	U.S.A.	USA-N
#05*1, #15*2	Italy	ITA-N
#06*1, #16*2	Europe	EUR-N

\*1 These versions are available for 136~150 MHz.

\*2 These versions are available for 150~174 MHz.

## DANGER

**NEVER** connect the repeater to a DC backup battery that uses more than 16 V. This will ruin the repeater.

**DO NOT** expose the repeater to rain, snow or any liquids.

**DO NOT** apply an RF signal of more than 20 dBm (100 mW) to the antenna connector. This could damage the repeater's front end.

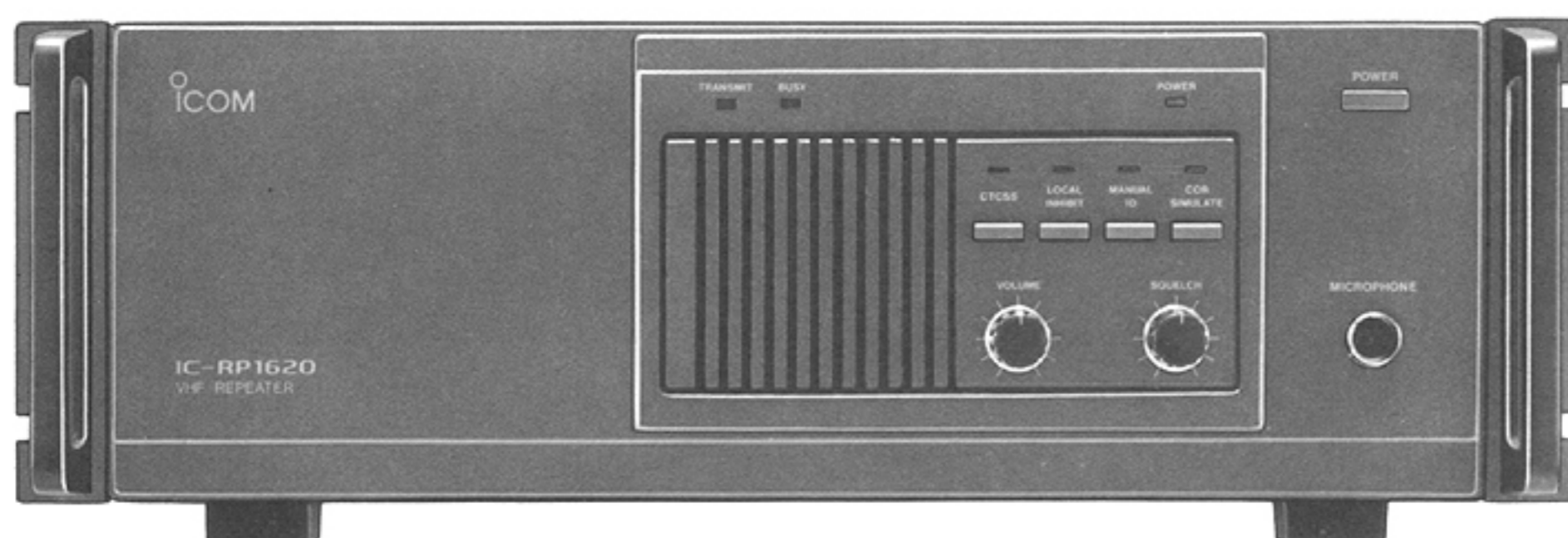

## ORDERING PARTS

Be sure to include the following four points when ordering replacement parts:

1. 10-digit order numbers
2. Component part number and name
3. Equipment model name and unit name
4. Quantity required

### <SAMPLE ORDER>

1110001000 IC  $\mu$ PC1651G IC-RP1620 TX UNIT 5 pieces  
8810004690 Screw BiH M4 x 5 ZK BS IC-RP1620 Top cover 10 pieces

Addresses are provided on the inside back cover for your convenience.

## REPAIR NOTE

1. Make sure a problem is internal before disassembling the repeater.
2. **DO NOT** open the repeater until the repeater is disconnected from the power source.
3. **DO NOT** force any of the variable components. Turn them slowly and smoothly.
4. **DO NOT** short any circuits or electronic parts. An insulated tuning tool **MUST** be used for all adjustments.
5. **DO NOT** keep power ON for a long time when the repeater is defective.
6. **DO NOT** transmit power into a signal generator or a sweep generator.
7. **ALWAYS** connect a 40 dB~50 dB attenuator between the repeater and a deviation meter or spectrum analyzer when using such test equipment.
8. **READ** the instructions of test equipment thoroughly before connecting equipment to the repeater.

## TABLE OF CONTENTS

<b>SECTION 1</b>	<b>SPECIFICATIONS</b> .....	<b>1—1</b>
<b>SECTION 2</b>	<b>INSIDE VIEWS</b> .....	<b>2—1</b>
<b>SECTION 3</b>	<b>CIRCUIT DESCRIPTION</b> .....	<b>3—1 ~ 5</b>
3-1	RECEIVER CIRCUITS .....	3—1
3-2	TRANSMITTER CIRCUITS .....	3—2
3-3	PLL CIRCUITS .....	3—3
3-4	DTMF DECODER CIRCUIT .....	3—4
3-5	REGULATOR CIRCUITS .....	3—4
3-6	OTHER CIRCUITS .....	3—5
<b>SECTION 4</b>	<b>MECHANICAL PARTS AND DISASSEMBLY</b> .....	<b>4—1 ~ 4</b>
4-1	FRONT PARTS .....	4—1
4-2	ACCESSORIES .....	4—1
4-3	CHASSIS PARTS .....	4—2
4-4	REAR PARTS .....	4—4
<b>SECTION 5</b>	<b>PARTS LIST</b> .....	<b>5—1 ~ 9</b>
<b>SECTION 6</b>	<b>ADJUSTMENT PROCEDURES</b> .....	<b>6—1 ~ 8</b>
6-1	PREPARATION BEFORE SERVICING .....	6—1
6-2	RX PLL ADJUSTMENT .....	6—2
6-3	TX PLL ADJUSTMENT .....	6—3
6-4	RECEIVER ADJUSTMENT .....	6—4
6-5	TRANSMITTER ADJUSTMENT .....	6—5
<b>SECTION 7</b>	<b>BOARD LAYOUTS</b> .....	<b>7—1 ~ 7</b>
7-1	FRONT UNIT .....	7—1
7-2	LOGIC-A UNIT .....	7—2
7-3	LOGIC UNIT .....	7—3
7-4	RX, R-VCO AND T-VCO UNITS .....	7—4
7-5	TX, R-DC-DC AND T-DC-DC UNITS .....	7—5
7-6	PA AND DIN UNITS .....	7—6
7-7	REG-A AND REG-B UNITS .....	7—7
<b>SECTION 8</b>	<b>VOLTAGE DIAGRAM</b> .....	<b>8—1</b>
<b>SECTION 9</b>	<b>BLOCK DIAGRAM</b> .....	<b>9—1</b>

To upgrade quality, all electrical and mechanical parts and internal circuits are subject to change without notice or obligation.

# SECTION 1 SPECIFICATIONS

## ■ GENERAL

- Frequency coverage : 136~150 MHz\* (low band version)  
150~174 MHz\* (high band version)  
\* Permitted frequency range differs according to countries.
- Mode : FM (16K0F3E)  
FM (8K50F3E) (narrow version)
- Initial tuning step : 5 or 12.5 kHz (selectable)
- Antenna impedance : 50  $\Omega$  (unbalanced)
- Power supply requirement : 

VERSION	VOLTAGE
U.S.A.	117 V AC or 13.8 V DC 15 % (negative ground)
Europe	240 V AC or 13.8 V DC 15 % (negative ground)
Italy	220 V AC or 13.8 V DC 15 % (negative ground)
- Power consumption (with AC power) : 160 VA
- Current drain (at 13.8 V DC) : Transmit 8.0 A  
Receive squelched 1.0 A  
Max. audio output 1.2 A
- Usable temperature range :  $-10^{\circ}\text{C}\sim+60^{\circ}\text{C}$  ( $+14^{\circ}\text{F}\sim+140^{\circ}\text{F}$ )
- Frequency stability :  $\pm 0.0001\%$  ( $-10^{\circ}\text{C}\sim+60^{\circ}\text{C}$ ;  $+14^{\circ}\text{F}\sim+140^{\circ}\text{F}$ )
- Dimensions : 425 (W)  $\times$  149 (H)  $\times$  368 (D) mm; 16.7 (W)  $\times$  5.9 (H)  $\times$  14.5 (D) in  
(Projections not included)
- Weight : 17 kg (37.5 lb)

## ■ TRANSMITTER

- Output power : 25 W
- Modulation system : Variable reactance frequency modulation
- Max. frequency deviation :  $\pm 5.0$  kHz  
 $\pm 2.5$  kHz (narrow version)
- Spurious emissions :  $-70$  dB
- Microphone impedance : 600  $\Omega$

## ■ RECEIVER

- Receive system : Double-conversion superheterodyne
- Intermediate frequencies : 1st 21.8 MHz  
2nd 455 kHz
- Sensitivity : 0.5  $\mu\text{V}$  for 12 dB SINAD
- Tight squelch sensitivity : 1.0  $\mu\text{V}$
- Adjacent channel selectivity :  $-70$  dB  
 $-60$  dB (narrow version)
- Spurious rejection :  $-70$  dB
- Audio output power : 1.7 W at 10 % distortion with an 8  $\Omega$  load
- Audio output impedance : 8  $\Omega$

A duplexer is separately required when only one antenna is used for operation.  
All stated specifications are subject to change without notice or obligation.

## SECTION 2 INSIDE VIEWS

### • TOP VIEW

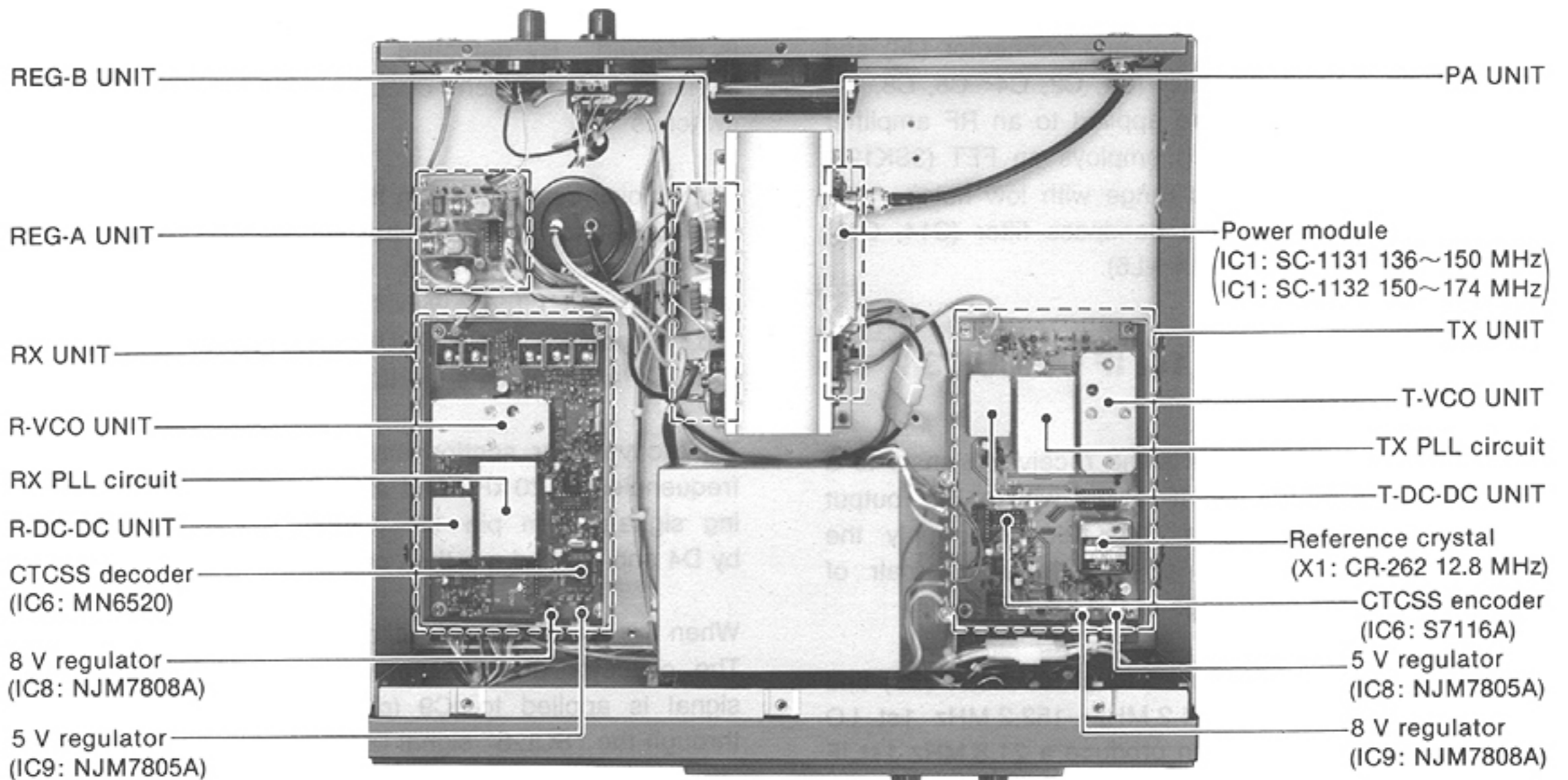

### • BOTTOM VIEW

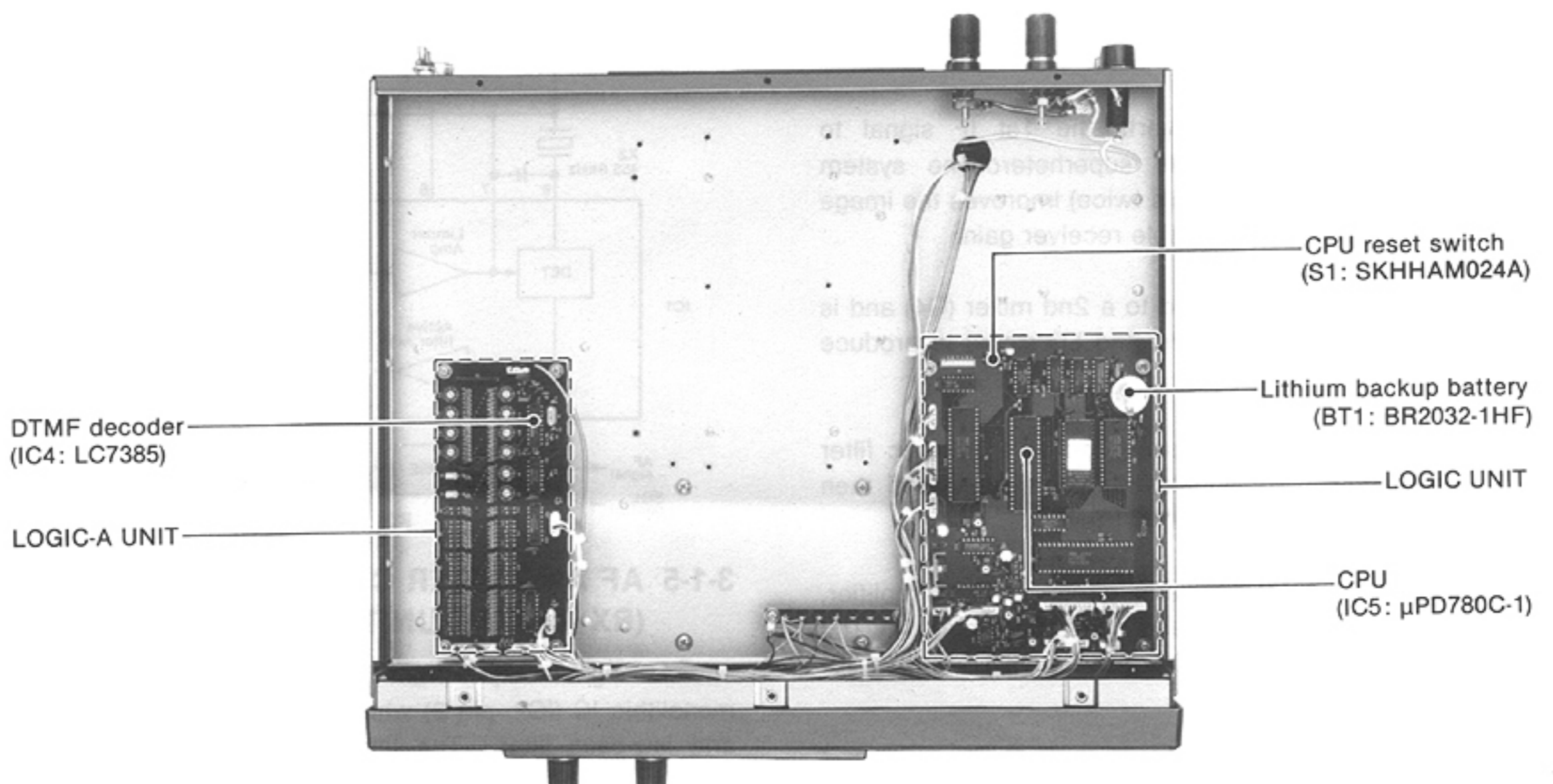

## SECTION 3 CIRCUIT DESCRIPTION

### 3-1 RECEIVER CIRCUITS

#### 3-1-1 RF CIRCUIT (RX UNIT)

Received signals enter the antenna connector (J6) and pass through a bandpass filter (C1, C2, C4~C6, C8, L1, L2). The filtered signals are applied to an RF amplifier (Q1). The RF amplifier (Q1) employs an FET (3SK121) which expands the dynamic range with low noise. The RF signals are applied to a bandpass filter (C14, C15, C17~C19, C21~C23, C25, L4~L6).

#### 3-1-2 1st MIXER AND 1st IF CIRCUITS (RX UNIT)

The 1st mixer circuit converts the received signals to a fixed frequency of the 1st IF signal with a PLL output frequency. By changing a PLL frequency, only the desired frequency can be passed through a pair of crystal filters at the next stage of the 1st mixer.

The filtered signals are applied to a 1st mixer (Q2) and are then mixed with a 114.2 MHz~152.2 MHz 1st LO signal from the PLL circuit to produce a 21.8 MHz 1st IF signal.

The 21.8 MHz 1st IF signal is applied to FI1. FI1 is an MCF (Monolithic Crystal Filter) which suppresses out-of-band signals. The 1st IF signal is applied to a 1st IF amplifier (Q3).

#### 3-1-3 2nd IF AND DEMODULATOR CIRCUITS (RX UNIT)

The 2nd mixer circuit converts the 1st IF signal to a 2nd IF signal. A double superheterodyne system (which converts receive signals twice) improves the image rejection ratio and obtains stable receiver gain.

The amplified signal is applied to a 2nd mixer (Q4) and is then mixed with a 21.345 MHz 2nd LO signal to produce a 455 kHz 2nd IF signal.

The 455 kHz 2nd IF signal is applied to a ceramic filter (FI2) where unwanted signals are suppressed and then to a limiter amplifier section in IC1 (pin 5).

IC1 contains the local oscillator circuit, limiter amplifier, quadrature detector circuit, and active filter circuit. The local oscillator section and X1 generate 21.345 MHz for the 2nd LO signal.

The 2nd IF signal from the limiter amplifier (IC1, pin 5) is applied to the quadrature detector section (IC1, pin 8 and ceramic discriminator X2) to demodulate the 2nd IF signal into an AF signal. The AF signal is output from IC1 (pin 9).

#### 3-1-4 SQUELCH CIRCUIT (RX AND LOGIC UNITS)

A squelch circuit cuts out AF signals when no RF signal is received. By detecting noise components in the AF signals, the squelch circuit switches the AF mute switches.

Some noise components in the AF signal from IC1 (pin 9) are applied to an active filter section (IC1, pin 10) via a de-emphasis circuit (R26, C51~C53). This circuit is an integrated circuit with frequency characteristics of -6 dB/octave. The [SQUELCH] control (R2) on the FRONT PANEL adjusts the IC1 (pin 10) input level.

The active filter section amplifies noise components of frequencies of 20 kHz and above and outputs the resulting signals from pin 11. Output signals are rectified by D4 and D5 and are then converted to DC voltage.

When the rectified noise voltage is "HIGH", Q5 turns ON. The collector of Q5 outputs the squelch signal. The signal is applied to IC9 (pin 16) on the LOGIC UNIT through the "SQL-S" signal line.

When the rectified noise voltage is "LOW", Q5 turns OFF. The collector of Q9 outputs the busy signal. The signal is applied to the [BUSY] indicator on the LED UNIT through the "BUSY" signal line. The [BUSY] indicator lights up in green.

#### • 2nd IF AND DEMODULATOR CIRCUITS

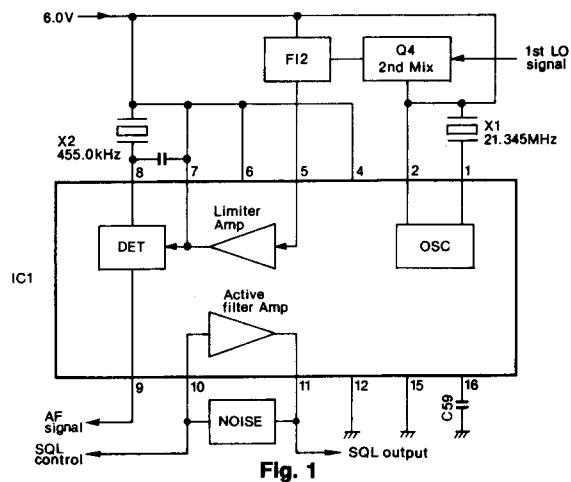

#### 3-1-5 AF AMPLIFIER CIRCUIT (RX AND AF UNITS)

The AF signal output from IC1 (pin 9) is applied to a monolithic IC (IC2, pin 3) which functions as a high-pass and low-pass filter. The filtered signal is output from IC2 (pin 7) and is then applied to the [VOLUME] control (R1) on the FRONT PANEL through an AF mute switch (Q6). When the squelch is closed, Q6 cuts off the AF signal as an AF mute switch. The AF signal is power-amplified at an AF power amplifier (IC1) on the AF UNIT to drive a speaker.

## 3-2 TRANSMITTER CIRCUITS

### 3-2-1 MICROPHONE AMPLIFIER CIRCUIT (TX AND T-VCO UNITS)

The AF signal from the microphone is applied to a microphone amplifier (IC10, pin 6). The amplified signal is output from IC10 (pin 7) and applied to IC10 (pin 2) to mix with the "MOD" signal from IC15 on the LOGIC UNIT. The signal is output from IC10 (pin 1) and applied to a limiter (IC7, pin 3). The AF signal obtains +6 dB/octave pre-emphasis at C53 and R51 which are connected to pin 2.

The output signal from IC7 (pin 1) is applied to the splatter filter circuit (IC7, R55, R59, R60, C56, C61, C62) which attenuates components of frequencies of 3 kHz and above. IC7 (pin 7) outputs an "MOD" signal. The "MOD" signal is applied to the T-VCO UNIT.

### 3-2-2 MODULATION CIRCUIT (T-VCO UNIT)

The modulation circuit modulates the VCO oscillating signal (RF signal) using the microphone audio signal.

The "MOD" signal from IC7 (pin 7) changes the reactance of varactor diode (D5) to modulate the oscillated signal at T-VCO (Q1). The oscillated signal is buffer-amplified at Q2 and is then applied to the drive amplifier circuit.

### 3-2-3 DRIVE AMPLIFIER CIRCUIT (TX AND PA UNITS)

The VCO output is buffer-amplified at IC1 and Q2. The signal is applied to the drive amplifier (Q1) on the PA UNIT. The drive amplifier (Q1) amplifies the signal to obtain 200 mW.

The control voltage from the APC circuit is applied to the collector of Q1 for stable RF output power from a power amplifier (IC1).

#### • APC CIRCUIT

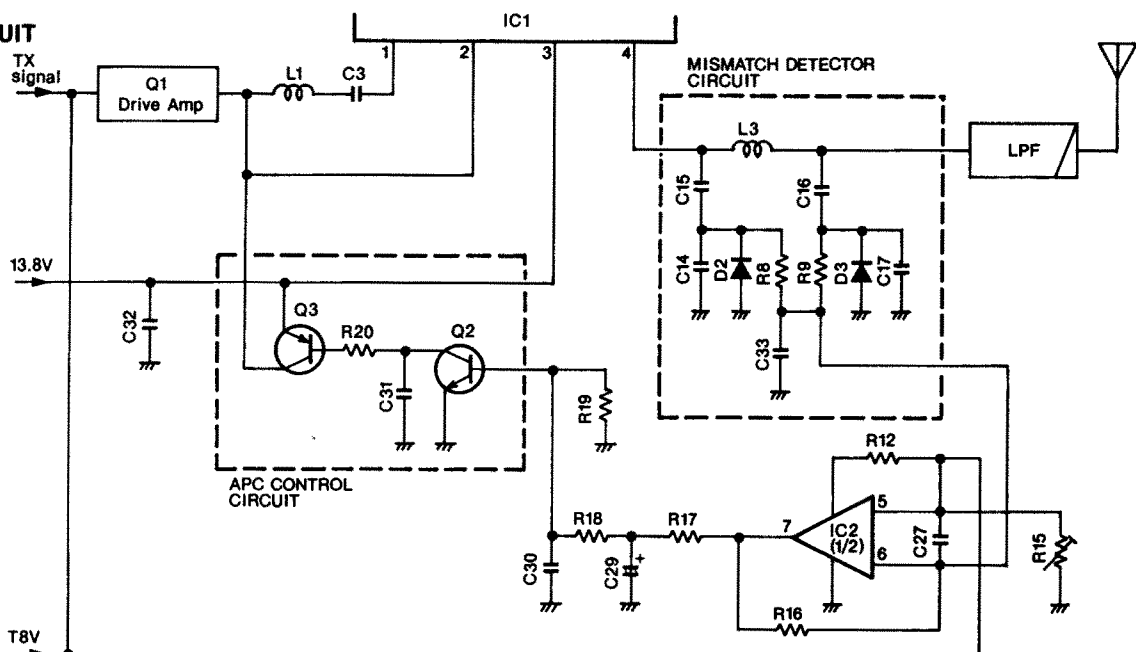

Fig. 2  
3 - 2

### 3-2-4 RF POWER AMPLIFIER (PA UNIT)

IC1 is a power module which provides a stable 25 W (DC 13.8 V) of output power.

An RF signal from the drive amplifier (Q1) is applied to IC1 (pin 1). The amplified signal is output from IC1 (pin 4) and applied to the antenna connector through the RF detector circuit and low-pass filter circuit.

### 3-2-5 APC CIRCUIT (PA UNIT)

This circuit controls a current of the power module's first stage and a current of the driver amplifier to obtain stable RF output power.

The APC mismatch detector circuit consists of C14~C17, D2, D3, L3, R8 and R9. When the antenna impedance is matched at 50  $\Omega$ , D2 and D3 detect the minimum voltage. The detected voltage is applied to a differential amplifier (IC2, pin 6). The APC reference voltage is applied to IC2 (pin 5).

When the antenna impedance is mismatched, the voltage in pin 6 of IC2 exceeds the reference voltage in pin 5 of IC2. The output level from IC2 (pin 7) decreases. Q2 amplifies the current from the differential amplifier (IC2) which controls Q3. Q3 changes the supply voltage to Q1 and IC1.

This decreases the output power from the drive amplifier (Q1) and power amplifier (IC1) until the input voltage in pin 6 of IC2 reaches the same level as pin 5 of IC2.

### 3-3 PLL CIRCUITS

#### 3-3-1 GENERAL

Each receiver and transmitter circuit has an independent PLL circuit for controlling frequencies. All PLL circuits are shielded and installed on the RX and TX UNITS.

PLL circuits steadily oscillate the transmit frequency and the receive local frequency. The PLL output frequency is controlled by the divided ratio (N-data) of the programmable divider.

#### 3-3-2 RECEIVER PLL CIRCUIT (RX UNIT)

The PLL circuit, using a PLL IC (IC3) and dual modulus prescaler (IC4) on the RX UNIT, generates the 1st LO frequency with a Colpitts VCO (Q1) on the R-VCO UNIT. The PLL IC sets the dividing ratio based on serial data from the CPU and controls the dual modulus prescaler. The PLL IC compares the phases of a VCO signal with the reference oscillator frequency and detects the out-of-step phase. Then, the VCO signal is output from the PLL IC (pin 16 and 17).

#### 3-3-3 RECEIVER REFERENCE OSCILLATOR CIRCUIT (RX AND TX UNITS)

A 12.8 MHz reference frequency is produced by the oscillator (X1) on the TX UNIT. The frequency is adjusted with R24. The reference frequency is buffer-amplified at Q5 and applied to the PLL IC (IC3, pin 2) on the RX UNIT.

#### 3-3-4 RECEIVER LOOP FILTER AND DC-DC CONVERTER CIRCUITS (RX AND R-DC-DC UNITS)

Phase-detected signals from IC3 (pin 16 and 17) are converted to DC voltage by a loop filter consisting of an active filter (Q10, Q11).

The frequency at which the VCO oscillates is controlled by varactor diodes (D1~D4) on the R-VCO UNIT. DC voltage (PLL lock voltage) is provided through the integrator circuit (R32, C110).

The DC-DC converter circuit (IC1 and Q1) on the R-DC-DC UNIT creates approximately 20 V DC from 5V DC to obtain wide range lock voltages for the PLL circuits.

#### 3-3-5 RECEIVER VCO CIRCUIT (R-VCO UNIT)

The VCO circuit (Q1, D1~D4) generates the receive frequency. Strip lines are used for stable oscillation over a wide frequency range. Varactor diodes (D1~D4) provide frequency control. The buffer amplifier (Q2) protects the PLL output signal from VCO oscillation. The signal is divided by 64 or 65 in the dual modulus prescaler (IC4). The phase-divided signal is output from IC4 (pin 5) and applied to the PLL IC (IC3, pin 6).

#### • PLL CIRCUITS

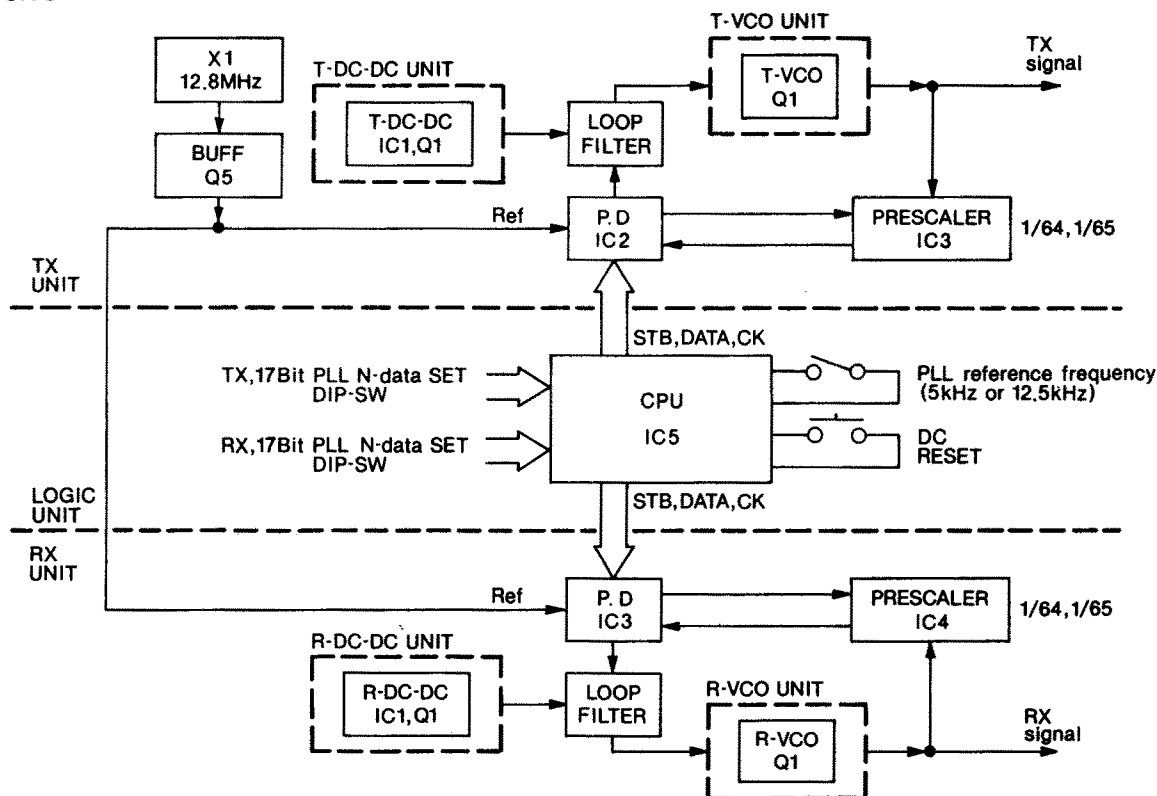

Fig. 3



### 3-3-6 RECEIVER UNLOCK SENSOR CIRCUIT (RX AND LOGIC UNITS)

When the PLL circuit is unlocked, IC3 (pin 13) becomes "HIGH". The "HIGH" signal is applied to IC9 (pin 14) as an unlock signal on the LOGIC UNIT.

### 3-3-7 TRANSMITTER PLL CIRCUIT (TX UNIT)

The PLL circuit, using a PLL IC (IC2) and dual modulus prescaler (IC3) on the TX UNIT, generates the transmit frequency with a Colpitts VCO (Q1) on the T-VCO UNIT. The PLL IC sets the dividing ratio based on serial data from the CPU and controls the dual modulus prescaler. The PLL IC compares the phases of a VCO signal with the reference oscillator frequency and detects the out-of-step phase. Then, the VCO signal is output from the PLL IC (pin 16 and 17).

### 3-3-8 TRANSMITTER REFERENCE OSCILLATOR CIRCUIT (TX UNIT)

A 12.8 MHz reference frequency is produced by the oscillator (X1). The frequency is adjusted with R24. The reference frequency is buffer-amplified at Q5 and applied to the PLL IC (IC2, pin 2).

### 3-3-9 TRANSMITTER LOOP FILTER AND DC-DC CONVERTER CIRCUITS (TX AND T-DC-DC UNITS)

Phase-detected signals from IC2 (pin 16 and 17) are converted to DC voltage by a loop filter consisting of an active filter (Q3, Q4).

The frequency at which the VCO oscillates is controlled by varactor diodes (D1~D4) on the T-VCO UNIT. DC voltage (PLL lock voltage) is provided through the integrator circuit (R15, C70).

The DC-DC converter circuit (IC1 and Q1) on the T-DC-DC UNIT creates approximately 20 V DC from 5 V DC to obtain wide range lock voltages for the PLL circuits.

### 3-3-10 TRANSMITTER VCO CIRCUIT (T-VCO UNIT)

The VCO circuit (Q1, D1~D4) generates the transmit frequency and produces FM modulation. Strip lines are used for stable oscillation over a wide frequency range. Varactor diodes (D1~D4) provide frequency control. The buffer amplifier (Q2) protects the PLL output signal from VCO oscillation. The signal is divided by 64 or 65 in the dual modulus prescaler (IC3). The phase-divided signal is output from IC3 (pin 5) and applied to the PLL IC (IC2, pin 6).

### 3-3-11 TRANSCEIVER UNLOCK SENSOR CIRCUIT (TX AND LOGIC UNITS)

When the PLL circuit is unlocked, IC2 (pin 13) becomes "HIGH". The "HIGH" signal is applied to IC9 (pin 15) as an unlock signal on the LOGIC UNIT.

### 3-4 DTMF DECODER CIRCUIT (LOGIC-A UNIT)

AF signals from the RX UNIT are fed to Q1 on the LOGIC-A UNIT through J5 and signals are amplified.

IC4 is an IC chip for the DTMF detector. An applied double-tone signal is detected at IC4 and outputs signals as a 4-bit binary code.

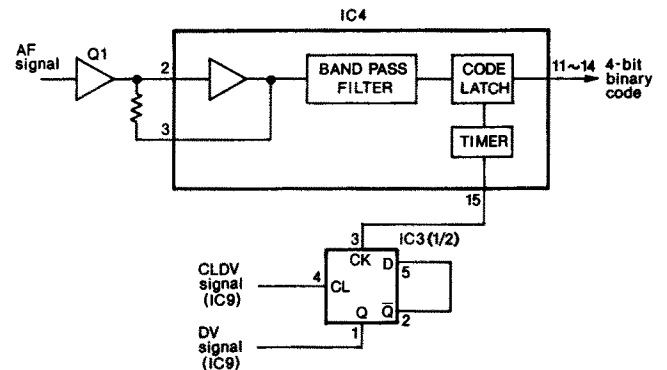

Fig. 4

### 3-5 REGULATOR CIRCUITS

The DC voltages are supplied from regulator circuits corresponding to the voltages. They are regulated at the following circuits using 13.8 V DC.

#### (1) 5 V REGULATOR (RX, TX, AND LOGIC UNITS)

5 V DC are regulated by the following three-terminal voltage regulators.

REGULATOR	IC8	IC9	IC16
UNIT	TX	RX	LOGIC

#### (2) 8 V regulator (RX AND TX UNITS)

8 V DC are regulated by the three-terminal voltage regulator.

#### • REGULATOR CIRCUITS

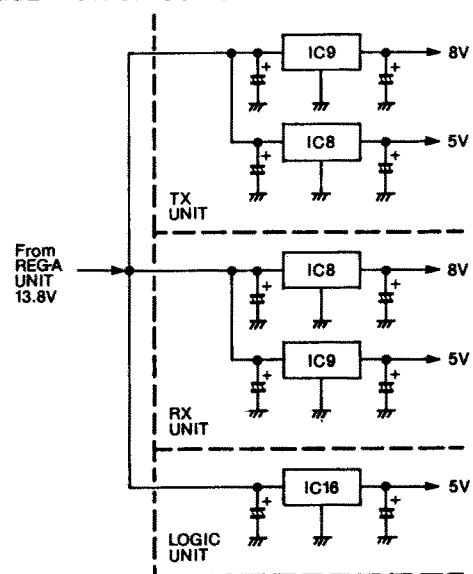

Fig. 5

## 3-6 OTHER CIRCUITS

### 3-6-1 CTCSS DECODER CIRCUIT (RX UNIT)

IC6 contains a CTCSS tone encoder/decoder, an AF amplifier circuit, and a two-stage AF filter. The encoder is not used in this circuit.

The AF signal from IC1 (pin 9) is applied to Q12. Q12 is an active filter which functions as a low-pass filter. The filtered signals are applied to a programmable CTCSS tone decoder (IC6, pin 29) which decodes 67.0 Hz ~250.3 Hz tone frequencies. The tone frequency is set by the dip switches (S3) on the LOGIC-A UNIT.

The AF signal from IC6 (pin 29) is applied to the AF amplifier circuit and then to the two-stage AF filter. The filtered signal is output as a tone squelch signal from IC6 (pin 23). The tone squelch signal is applied to IC9 (pin 17) on the LOGIC UNIT through the "T-SQL" signal line.

IC7 functions as a serial/parallel converter and supplies 8-bit parallel data to IC6 (pin 3~6). The following table shows the relation between the input data and output frequency from IC6.

#### • CTCSS TONE DECODER FREQUENCY TABLE

TONE NUMBER	TONE FREQUENCY (Hz)	S3						TONE NUMBER	TONE FREQUENCY (Hz)	S3						TONE NUMBER	TONE FREQUENCY (Hz)	S3					
		1	2	3	4	5	6			1	2	3	4	5	6			1	2	3	4	5	6
01	67.0	ON	—	—	—	—	—	14	107.2	—	ON	ON	ON	—	—	27	167.9	ON	ON	—	ON	ON	—
02	71.9	—	ON	—	—	—	—	15	110.9	ON	ON	ON	ON	—	—	28	173.8	—	—	ON	ON	ON	—
03	74.4	ON	ON	—	—	—	—	16	114.8	—	—	—	—	ON	—	29	179.9	ON	—	ON	ON	ON	—
04	77.0	—	—	ON	—	—	—	17	118.8	ON	—	—	—	ON	—	30	186.2	—	ON	ON	ON	ON	—
05	79.7	ON	—	ON	—	—	—	18	123.0	—	ON	—	—	ON	—	31	192.8	ON	ON	ON	ON	ON	—
06	82.5	—	ON	ON	—	—	—	19	127.3	ON	ON	—	—	ON	—	32	203.5	—	—	—	—	—	ON
07	85.4	ON	ON	ON	—	—	—	20	131.8	—	—	ON	—	ON	—	33	210.7	ON	—	—	—	—	ON
08	88.5	—	—	—	ON	—	—	21	136.5	ON	—	ON	—	ON	—	34	218.1	—	ON	—	—	—	ON
09	91.5	ON	—	—	ON	—	—	22	141.3	—	ON	ON	—	ON	—	35	225.7	ON	ON	—	—	—	ON
10	94.8	—	ON	—	ON	—	—	23	146.2	ON	ON	ON	—	ON	—	36	233.6	—	—	ON	—	—	ON
11	97.4	No assigned						24	151.4	—	—	—	ON	ON	—	37	241.8	ON	—	ON	—	—	ON
12	100.0	—	—	ON	ON	—	—	25	156.7	ON	—	—	ON	ON	—	38	250.3	—	ON	ON	—	—	ON
13	103.5	ON	—	ON	ON	—	—	26	162.2	—	ON	—	ON	ON	—								

—: OFF

### 3-6-2 CTCSS ENCODER CIRCUIT (TX UNIT)

The CTCSS encoder (IC6) encodes 67.0 Hz~250.3 Hz tone frequencies which are set by the dip switches (S11) on the LOGIC-A UNIT. The tone frequency is output from IC6 (pin 1) and then applied to R32 for the deviation adjustment.

IC5 functions as a serial/parallel converter and supplies 8-bit parallel data to IC6. The following table shows the relation between input data and the output frequency from IC6.

#### • CTCSS TONE ENCODER FREQUENCY TABLE

TONE NUMBER	TONE FREQUENCY (Hz)	S11						TONE NUMBER	TONE FREQUENCY (Hz)	S11						TONE NUMBER	TONE FREQUENCY (Hz)	S11					
		1	2	3	4	5	6			1	2	3	4	5	6			1	2	3	4	5	6
01	67.0	ON	—	—	—	—	—	14	107.2	—	ON	ON	ON	—	—	27	167.9	ON	ON	—	ON	ON	—
02	71.9	—	ON	—	—	—	—	15	110.9	ON	ON	ON	ON	—	—	28	173.8	—	—	ON	ON	ON	—
03	74.4	ON	ON	—	—	—	—	16	114.8	—	—	—	—	ON	—	29	179.9	ON	—	ON	ON	ON	—
04	77.0	—	—	ON	—	—	—	17	118.8	ON	—	—	—	ON	—	30	186.2	—	ON	ON	ON	ON	—
05	79.7	ON	—	ON	—	—	—	18	123.0	—	ON	—	—	ON	—	31	192.8	ON	ON	ON	ON	ON	—
06	82.5	—	ON	ON	—	—	—	19	127.3	ON	ON	—	—	ON	—	32	203.5	—	—	—	—	—	ON
07	85.4	ON	ON	ON	—	—	—	20	131.8	—	—	ON	—	ON	—	33	210.7	ON	—	—	—	—	ON
08	88.5	—	—	—	ON	—	—	21	136.5	ON	—	ON	—	ON	—	34	218.1	—	ON	—	—	—	ON
09	91.5	ON	—	—	ON	—	—	22	141.3	—	ON	ON	—	ON	—	35	225.7	ON	ON	—	—	—	ON
10	94.8	—	ON	—	ON	—	—	23	146.2	ON	ON	ON	—	ON	—	36	233.6	—	—	ON	—	—	ON
11	97.4	ON	ON	—	ON	—	—	24	151.4	—	—	—	ON	ON	—	37	241.8	ON	—	ON	—	—	ON
12	100.0	—	—	ON	ON	—	—	25	156.7	ON	—	—	ON	ON	—	38	250.3	—	ON	ON	—	—	ON
13	103.5	ON	—	ON	ON	—	—	26	162.2	—	ON	—	ON	ON	—								

—: OFF

# SECTION 4 MECHANICAL PARTS AND DISASSEMBLY

## 4-1 FRONT PARTS

LABEL NUMBER	ORDER NO.	DESCRIPTION	QTY.
①	8210006340	Front panel (G)	1
②	8310017750	Front plate	1
③	8010008901	695 sub chassis-1	1
④	8930015660	695 speaker plate	1
⑤	8810001110	Screw PH B0 M3 × 6	13
⑥	8850000130	Flat washer M3 (3 × 8 × 0.5) NI BS	9
⑦	8930000070	Standoff (D)	2
⑧	8850000420	Spring washer M3 NI	2
⑨	8810003160	Setscrew A M3 × 6	5
⑩	8810004270	Screw BIH M4 × 6 ZK BS	4
⑪	8810003360	Setscrew C M3 × 6	2
⑫	2230000120	Switch SDDSA3159A [POWER]	1
⑬	2510000040	Speaker C065K12I0810	1
⑭	8610004170	Knob N122 [VOLUME], [SQUELCH]	2
⑮	8610002840	Button K79 [POWER]	1
⑯	8610005840	Button K89 (B) [CTCSS], [LOCAL INHIBIT], etc.	4
⑰	8810005290	Spring washer for FM 214	1
⑱	2230000380	Switch SPUE44067A [CTCSS], [LOCAL INHIBIT], etc.	1
⑲	5040000470	LED SPB-26MUW F [POWER]	1
⑳	5040001310	LED SLB-26UR 3F [TRANSMIT]	1
㉑	5040001130	LED SLB-26MG 3F [BUSY]	1
㉒	5040001360	LED TLG205 [CTCSS]	1
㉓	5040000650	LED TLY205 [LOCAL INHIBIT]	1
㉔	5040000640	LED TLR205 [MANUAL ID]	1
㉕	5040000650	LED TLY205 [COR SIMULATE]	1
㉖	8410000030	AF heatsink	1
㉗	7210000140	Variable resistor RK1631110D9DA [VOLUME]	1
㉘	7210000690	Variable resistor RK1631110D9CA [SQUELCH]	1
㉙	6510004820	Mic connector FM14RS-7SS [MICROPHONE]	1

**Screw abbreviations** B0: Self-tapping screw BiH: Binding head PH: Pan head BS: Brass  
 NI: Nickel ZK: Black

## 4-2 ACCESSORIES

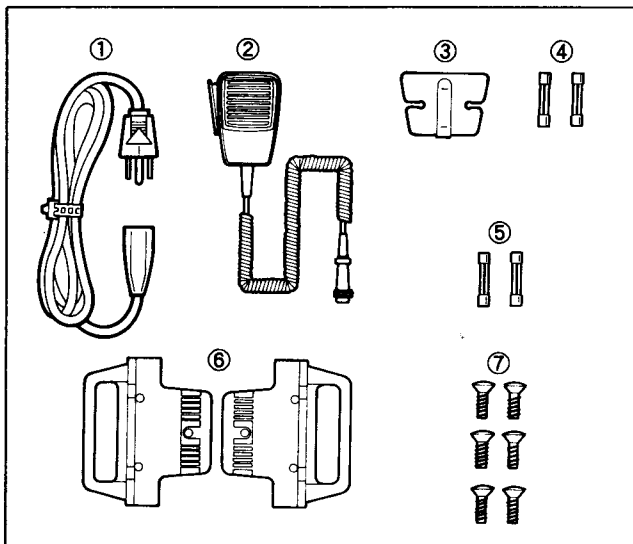

LABEL NUMBER	ORDER NO.	DESCRIPTION	QTY.
①	8900000710	AC power cable OPC-048 A (EUR-W, EUR-N, ITA-W, ITA-N)	1
	8900000330	AC power cable OPC-034 (USA-W, USA-N)	1
②	Optional product	Microphone (HM-4)	1
③	8930007300	Microphone hook	1
④	5210000050	Spare fuses for AC line FGB 3A	2
⑤	5210000070	Spare fuses for DC line FGB 10A	2
⑥	8010006700	Rack mounting handles	2
⑦	8810006110	Screw OH M4 × 9 ZK	6

**Screw abbreviations** OH: Oval countersunk head  
 ZK: Black

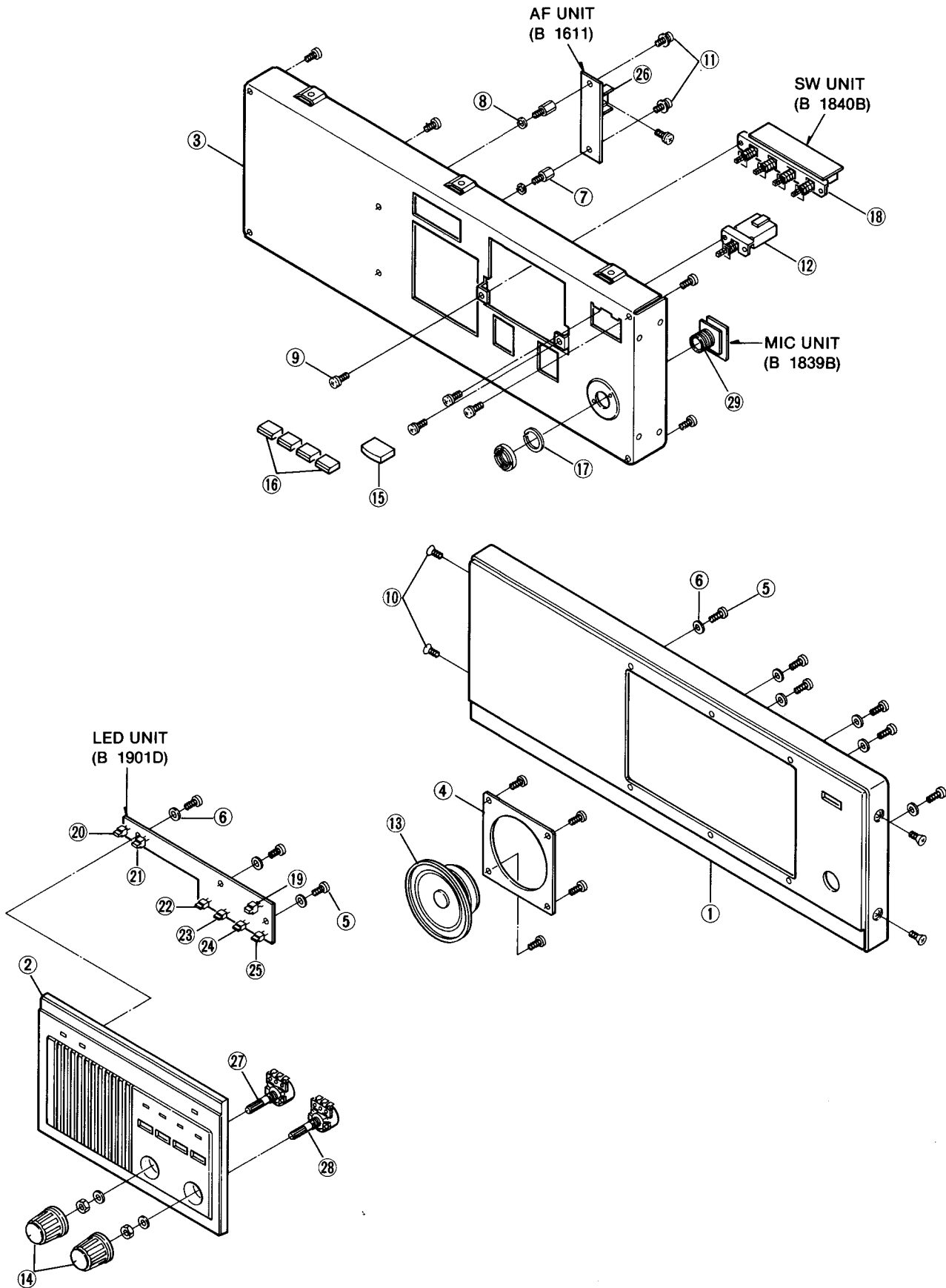

## 4-3 CHASSIS PARTS

LABEL NUMBER	ORDER NO.	DESCRIPTION	QTY.
①	8010008911	695 chassis-1	1
②	8010008920	695 chassis (right side)	1
③	8010008930	695 chassis (left side)	1
④	8810002210	Screw FH M4 × 6	10
⑤	8930000230	Standoff (S)	6
⑥	8850000420	Spring washer M3 NI	17
⑦	8860000130	Grounding lug B5 (M3) AG BS	3
⑧	8810003360	Setscrew C M3 × 6	33
⑨	8930000070	Standoff (D)	11
⑩	8810003380	Setscrew C M3 × 10	8
⑪	8510006020	695 transformer shield plate	1
⑫	8930016040	Standoff (AZ)	4
⑬	8510006300	695 shield plate (A)	1
⑭	8110003790	695 transformer shield cover	1
⑮	8810003390	Setscrew C M4 × 8	4
⑯	8110003430	695 top cover	1
⑰	8110003441	695 bottom cover-1	1
⑱	8810004690	Screw BiH M4 × 5 ZK BS	18
⑲	8930011680	Rubber foot (G)	4
⑳	8810000390	Screw PH M4 × 12	4
㉑	8510001080	Shield case (A)	2
㉒	8510001101	Shield case (A) cover (A)-1	2
㉓	8510005870	695 shield case	2
㉔	8510005880	695 shield case top cover	2
㉕	8510005890	695 shield case bottom cover	2
㉖	8810003160	Setscrew A M3 × 6	7
㉗	8830000100	Nut M3	4
㉘	8410001460	696-10 heatsink	1
㉙	8410001360	695 heatsink BKT	2
㉚	8810003370	Setscrew C M3 × 8	1
㉛	8810003760	Icom screw C10	5
㉜	8930006080	Screw spacer-C	5
㉝	8510004181	443 10W module shield plate-2	1
㉞	8930011460	566 PA module plate	1
㉟	8810003170	Setscrew A M3 × 8	3
㊱	8810000420	Screw PH M4 × 18	1
㊲	8850000430	Spring washer M4 NI	1
㊳	8850000140	Flat washer M4 NI BS	1
㊴	8810003370	Setscrew C M3 × 8	1
㊵	8950001760	Electrical tape No. 1245 L=70	1
㊶	8930011250	Transistor sheet TO-3P	2
㊷	8510000020	194 shield case	5
㊸	6510000570	Terminal ML-18 7P	3
㊹	8510006300	695 shield plate (A)	1
㊺	4510000360	Electrolytic condenser HCG5A1E563Y (25L56000UF)	1
㊻	5910000600	Transformer TP-52	1

**Screw abbreviations** FH: Flat head BiH: Binding head PH: Pan head BS: Brass  
 NI: Nickel ZK: Black

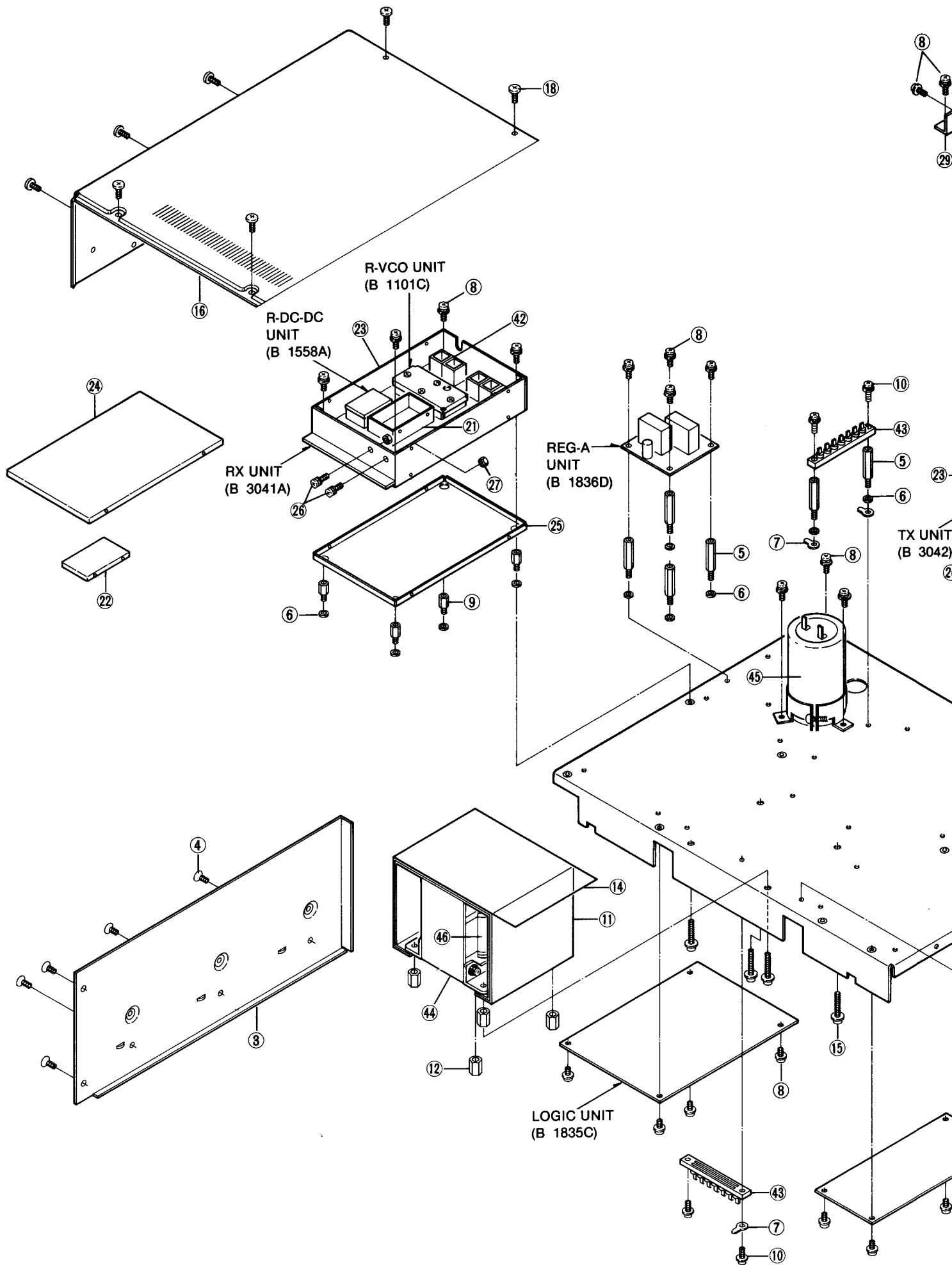

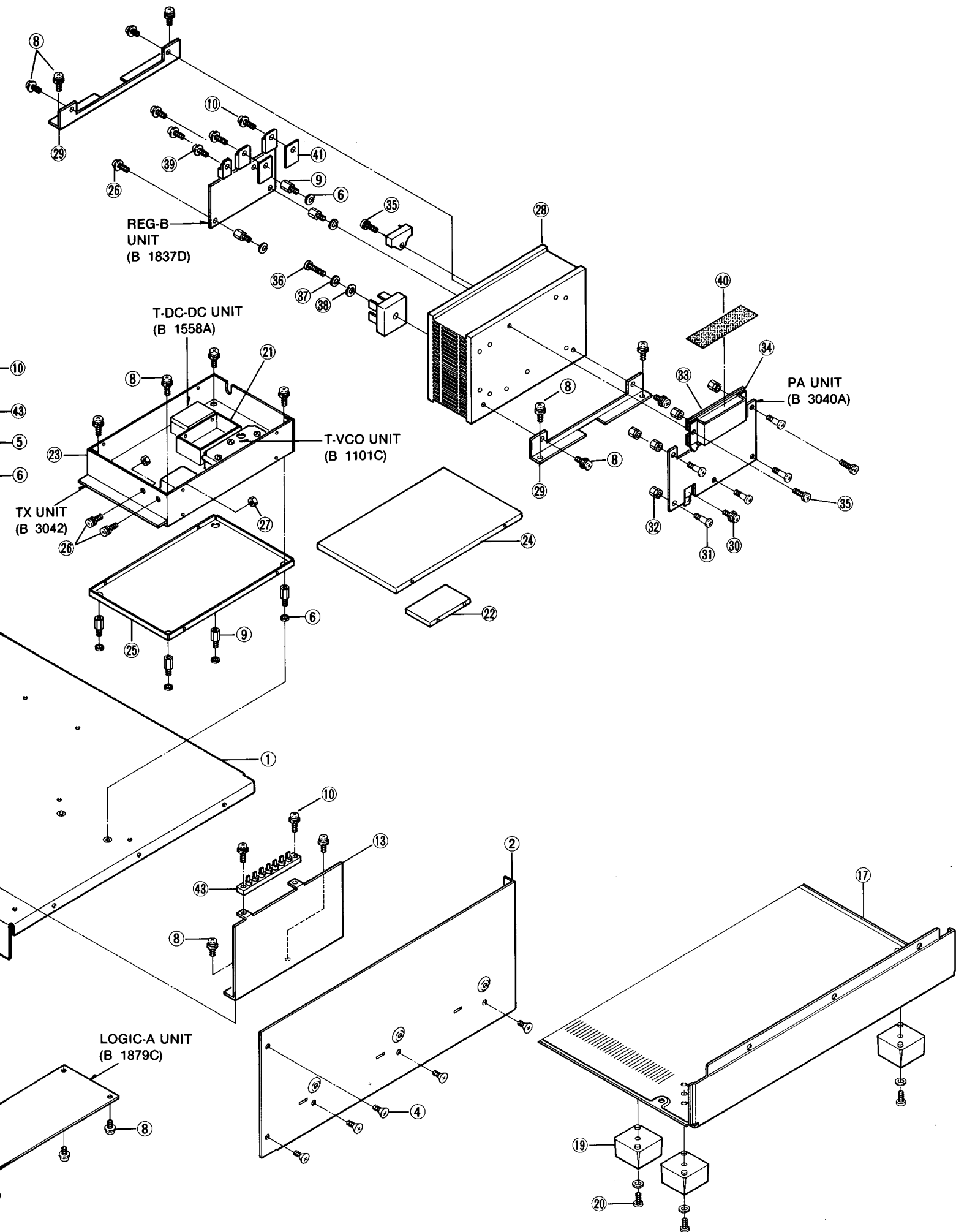

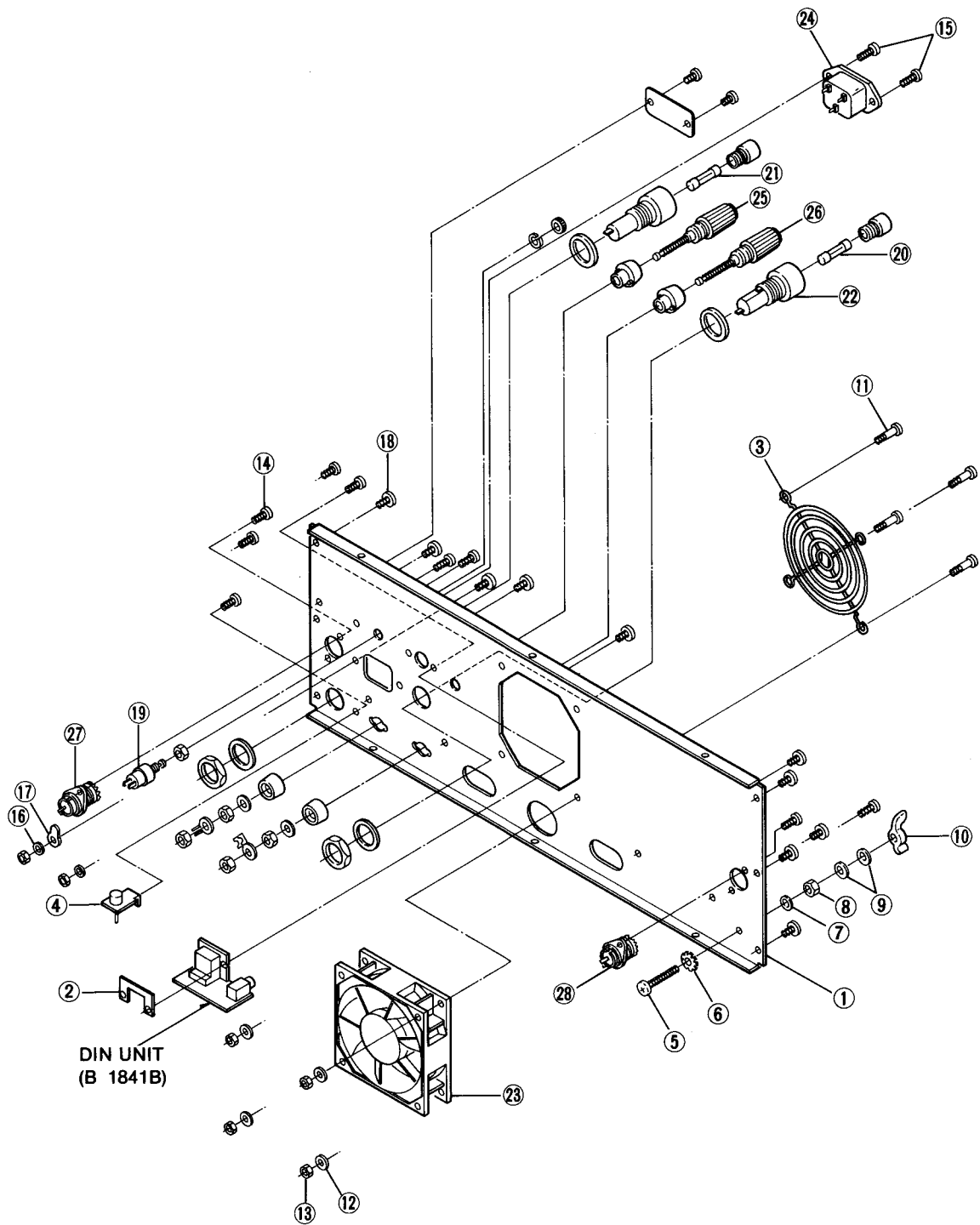



## 4-4 REAR PARTS

LABEL NUMBER	ORDER NO.	DESCRIPTION	QTY.
①	8010008941	695 rear panel-1	1
②	8930008230	DIN plate	1
③	6910003290	Finger guard B-1	1
④	8930002360	Diode plate	1
⑤	8810001990	Screw PH M5 × 18 NI BS	1
⑥	8850000590	Star washer M5	1
⑦	8850000440	Spring washer M5 NI	1
⑧	8830000210	Nut M5 NI BS	1
⑨	8850000150	Flat washer M5 NI BS	2
⑩	8830000360	Wing nut M5 NI	1
⑪	8810003770	Icom screw C12	4
⑫	8850000130	Flat washer M3 (3 × 8 × 0.5) NI BS	4
⑬	8830000100	Nut M3	6
⑭	8810003720	Icom screw B6	7
⑮	8810003740	Icom screw B10	2
⑯	8850000420	Spring washer M3 NI	2
⑰	8860000130	Grounding lug B5 (M3) AG BS	1
⑱	8810004270	Screw BiH M4 × 6 ZK BS	10
⑲	2230000710	Switch DS-102-R [DC RESET]	1
⑳	5210000050	Fuse FGB 3A [AC FUSE]	1
㉑	5210000070	Fuse FGB 10A [DC FUSE]	1
㉒	5220000051	Fuse holder FH-032CT	2
㉓	2710000280	Fan MD1208PTS-1	1
㉔	6450000770	Jack CM-11 [AC]	1
㉕	6510000460	Terminal T3830 R [BACKUP BATTERY (+)]	1
㉖	6510000470	Terminal T3830 K [BACKUP BATTERY (-)]	1
㉗	6510000410	ANT. connector MR-DS-E 02 [RX ANT]	1
㉘	6510000410	ANT. connector MR-DS-E 02 [TX ANT]	1

**Screw abbreviations**    BiH: Binding head    PH: Pan head    BS: Brass    NI: Nickel    ZK: Black

# SECTION 5 PARTS LIST

## [FRONT UNIT]

REF. NO.	ORDER NO.	DESCRIPTION	
R1	7210000140	Variable Resistor	RK1631110D9DA (10KA) [VOLUME]
R2	7210000690	Variable Resistor	RK1631110D9CA (10KB) [SQUELCH]
S1	2230000120	Switch	SDDSA3159A [POWER]
SP1	2510000040	Speaker	C065K12I0810 [SPEAKER]

## [LED UNIT]

REF. NO.	ORDER NO.	DESCRIPTION	
R1	7010003400	Resistor	ELR20J 1 k $\Omega$
R2	7010003400	Resistor	ELR20J 1 k $\Omega$
R3	7010003400	Resistor	ELR20J 1 k $\Omega$
R4	7010003400	Resistor	ELR20J 1 k $\Omega$
R5	7010003400	Resistor	ELR20J 1 k $\Omega$
R6	7010003400	Resistor	ELR20J 1 k $\Omega$
DS1	5040000470	LED	SPB-26MUW F [POWER]
DS2	5040001310	LED	SLB-26UR 3F [TRANSMIT]
DS3	5040001130	LED	SLB-26MG 3F [BUSY]
DS4	5040001360	LED	TLG205 [CTCSS]
DS5	5040000650	LED	TLY205 [LOCAL INHIBIT]
DS6	5040000640	LED	TLR205 [MANUAL ID]
DS7	5040000650	LED	TLY205 [COR SIMULATE]
EP1	0910020104	P.C. Board	B 1901D (LED)

## [MIC UNIT]

REF. NO.	ORDER NO.	DESCRIPTION	
EP1	0910019801	P.C. Board	B 1839B (MIC)

## [CHASSIS UNIT]

REF. NO.	ORDER NO.	DESCRIPTION	
D1	1710000010	Diode	15CD11
D2	1730000070	Zener	RD3.9E B2
R1	7010004650	Resistor	R50XJ 10 $\Omega$
C1	4510000360	Electrolytic	HCG5A1E563Y (25L5 6000 $\mu$ F)
C2	4010004440	Ceramic	DE7090 B 102K VA1-KC
C3	4010004440	Ceramic	DE7090 B 102K VA1-KC
S1	2230000710	Switch	DS-102-R
F1	5220000051	Holder	FH-032CT
F2	5220000051	Holder	FH-032CT
EP3	6510000570	Lead Frame	ML-18 7P
EP4	6510000570	Lead Frame	ML-18 7P
EP5	6510000570	Lead Frame	ML-18 7P

## [AF UNIT]

REF. NO.	ORDER NO.	DESCRIPTION	
IC1	1110000200	IC	$\mu$ PC2002V
R1	7010003280	Resistor	ELR20J 100 $\Omega$
R2	7010003080	Resistor	ELR20J 2.2 $\Omega$
R3	7010003320	Resistor	ELR20J 220 $\Omega$
R4	7010003480	Resistor	ELR20J 4.7 k $\Omega$
C1	4510000830	Electrolytic	16 RE 220 $\mu$ F
C2	4040000260	Barrier Layer	UZE 08X 104M
C3	4510000830	Electrolytic	16 RE 220 $\mu$ F
C4	4510000820	Electrolytic	16 RE 100 $\mu$ F
C5	4010000520	Ceramic	DD108 B 472K 50V
C6	4510000890	Electrolytic	50 RE 0.47 $\mu$ F
EP1	0910017010	P.C. Board	B 1611 (AF)

## [SW UNIT]

REF. NO.	ORDER NO.	DESCRIPTION	
S1	2230000380	Switch	SPUE44067A [CTCSS, etc.]
EP1	0910019832	P.C. Board	B 1840B (SW)

## [LOGIC-A UNIT]

REF. NO.	ORDER NO.	DESCRIPTION	
IC1	1130003960	IC	$\mu$ PD74HC238C
IC2	1130003960	IC	$\mu$ PD74HC238C
IC3	1130000750	IC	$\mu$ PD4013BC

## [LOGIC-A UNIT]

REF. NO.	ORDER NO.	DESCRIPTION	
IC4	1130004680	IC	LC7385 (DIP)
Q1	1530000040	Transistor	2SC1815-Y
D1	1710000160	Diode	1SS133
D2	1710000160	Diode	1SS133
D3	1710000160	Diode	1SS133
D4	1710000160	Diode	1SS133
D5	1710000160	Diode	1SS133
D6	1710000160	Diode	1SS133
D7	1710000160	Diode	1SS133
D8	1710000160	Diode	1SS133
D9	1710000160	Diode	1SS133
D10	1710000160	Diode	1SS133
D11	1710000160	Diode	1SS133
D12	1710000160	Diode	1SS133
D13	1710000160	Diode	1SS133
D14	1710000160	Diode	1SS133
D15	1710000160	Diode	1SS133
D16	1710000160	Diode	1SS133
D17	1710000160	Diode	1SS133
D18	1710000160	Diode	1SS133
D19	1710000160	Diode	1SS133
D20	1710000160	Diode	1SS133
D21	1710000160	Diode	1SS133
D22	1710000160	Diode	1SS133
D23	1710000160	Diode	1SS133
D24	1710000160	Diode	1SS133
D25	1710000160	Diode	1SS133
D26	1710000160	Diode	1SS133
D27	1710000160	Diode	1SS133
D28	1710000160	Diode	1SS133
D29	1710000160	Diode	1SS133
D30	1710000160	Diode	1SS133
D31	1710000160	Diode	1SS133
D32	1710000160	Diode	1SS133
D33	1710000160	Diode	1SS133
D34	1710000160	Diode	1SS133
D35	1710000160	Diode	1SS133
D36	1710000160	Diode	1SS133
D37	1710000160	Diode	1SS133
D38	1710000160	Diode	1SS133
D39	1710000160	Diode	1SS133
D40	1710000160	Diode	1SS133
D41	1710000160	Diode	1SS133
D42	1710000160	Diode	1SS133
D43	1710000160	Diode	1SS133
D44	1710000160	Diode	1SS133
D45	1710000160	Diode	1SS133
D46	1710000160	Diode	1SS133
D47	1710000160	Diode	1SS133
D48	1710000160	Diode	1SS133
D49	1710000160	Diode	1SS133
D50	1710000160	Diode	1SS133
D51	1710000160	Diode	1SS133
D52	1710000160	Diode	1SS133
D53	1710000160	Diode	1SS133
D54	1710000160	Diode	1SS133
D55	1710000160	Diode	1SS133
D56	1710000160	Diode	1SS133
D57	1710000160	Diode	1SS133
D58	1710000160	Diode	1SS133
D59	1710000160	Diode	1SS133
D60	1710000160	Diode	1SS133
D61	1710000160	Diode	1SS133
D62	1710000160	Diode	1SS133
D63	1710000160	Diode	1SS133
D64	1710000160	Diode	1SS133
D65	1710000160	Diode	1SS133
D66	1710000160	Diode	1SS133
D67	1710000160	Diode	1SS133
D68	1710000160	Diode	1SS133
D69	1710000160	Diode	1SS133

## [LOGIC-A UNIT]

REF. NO.	ORDER NO.	DESCRIPTION	
D70	1710000160	Diode	1SS133
D71	1710000160	Diode	1SS133
D72	1710000160	Diode	1SS133
D73	1710000160	Diode	1SS133
D74	1710000160	Diode	1SS133
D75	1710000160	Diode	1SS133
D76	1710000160	Diode	1SS133
D77	1710000160	Diode	1SS133
D78	1710000160	Diode	1SS133
D79	1710000160	Diode	1SS133
D80	1710000160	Diode	1SS133
D81	1710000160	Diode	1SS133
D82	1710000160	Diode	1SS133
D83	1710000160	Diode	1SS133
D84	1710000160	Diode	1SS133
D85	1710000160	Diode	1SS133
D86	1710000160	Diode	1SS133
D87	1710000160	Diode	1SS133
D88	1710000160	Diode	1SS133
D89	1710000160	Diode	1SS133
D90	1710000160	Diode	1SS133
D91	1710000160	Diode	1SS133
D92	1710000160	Diode	1SS133
D93	1710000160	Diode	1SS133
D94	1710000160	Diode	1SS133
D95	1710000160	Diode	1SS133
D96	1710000160	Diode	1SS133
D97	1710000160	Diode	1SS133
X1	6050003120	Crystal	RF-4A3 FAA NKD (3.579545M)
R1	7010003620	Resistor	ELR20J 47 kΩ
R2	7010003630	Resistor	ELR20J 56 kΩ
R3	7010003620	Resistor	ELR20J 47 kΩ
R4	7010003360	Resistor	ELR20J 470 Ω
R5	7010003620	Resistor	ELR20J 47 kΩ
R6	7010003530	Resistor	ELR20J 10 kΩ
R7	7010003400	Resistor	ELR20J 1 kΩ
R8	7010003320	Resistor	ELR20J 220 Ω
R9	7410000210	Resistor Array	RMX- 8 472K
R10	7010003700	Resistor	ELR20J 220 kΩ
R11	7010003620	Resistor	ELR20J 47 kΩ
C1	4040000260	Barrier Layer	UZE 08X 104M
C2	4040000260	Barrier Layer	UZE 08X 104M
C3	4010000220	Ceramic	DD104 SL 330J 50V
C4	4010000220	Ceramic	DD104 SL 330J 50V
C5	4040000260	Barrier Layer	UZE 08X 104M
C6	4310000020	Mylar	F2D 50V 103K
C7	4550002880	Tantalum	DN 1V 0R1K
C8	4010000500	Ceramic	DD104 B 102K 50V
C9	4040000260	Barrier Layer	UZE 08X 104M
S1	2260001100	Switch	SSGM1A031A
S2	2260000610	Switch	SSGM17012A
S3	2260000820	Switch	SSGM16034A
S4	2260000790	Switch	SSGM12026A
S5	2260000580	Switch	SKHLAD035A
S6	2260000580	Switch	SKHLAD035A
S7	2260001090	Switch	DRS3016
S8	2260001090	Switch	DRS3016
S9	2260001100	Switch	SSGM1A031A
S10	2260000610	Switch	SSGM17012A
S11	2260000820	Switch	SSGM16034A
S12	2260000790	Switch	SSGM12026A
S13	2260001090	Switch	DRS3016
S14	2260001090	Switch	DRS3016
S15	2260001090	Switch	DRS3016
S16	2260001090	Switch	DRS3016
S17	2260001090	Switch	DRS3016

[LOGIC-A UNIT]

REF. NO.	ORDER NO.	DESCRIPTION	
S18	2260001090	Switch	DRS3016
S19	2260001090	Switch	DRS3016
S20	2260001090	Switch	DRS3016
EP1	0910019533	P.C. Board	B 1879C (LOGIC-A)

[LOGIC UNIT]

REF. NO.	ORDER NO.	DESCRIPTION	
IC1	1130001270	IC	μPD4069UBC
IC2	1130003970	IC	μPD74HC393C
IC3	1130003320	IC	μPD74HC4040C
IC4	1130003950	IC	μPD74HC14C
IC5	1140000490	IC	μPD780C-1
IC6	1130003620	IC	μPD74HC32C
IC7	1130003700	IC	μPD27C256AD
IC8	1130003930	IC	μPD4464C
IC9	1130002640	IC	μPD71055C
IC10	1130002640	IC	μPD71055C
IC11	1110001750	IC	BA614
IC12	1110001750	IC	BA614
IC13	1130000040	IC	TC4011UBP
IC14	1110000540	IC	NJM4558D
IC15	1110000540	IC	NJM4558D
IC16	1180000190	IC	NJM7805A
IC17	1110001680	IC	S-8054ALB
Q1	1530000960	Transistor	2SC3399
Q2	1530000960	Transistor	2SC3399
Q3	1530000110	Transistor	2SC2458-GR
Q4	1530000960	Transistor	2SC3399
Q5	1530000960	Transistor	2SC3399
Q6	1590000310	FET	2SJ105-GR
D2	1710000160	Diode	1SS133
D3	1710000160	Diode	1SS133
D4	1710000160	Diode	1SS133
D5	1710000160	Diode	1SS133
X1	6060000380	Crystal	CSA4.00MG
R1	7010003780	Resistor	ELR20J 1 MΩ
R4	7010003620	Resistor	ELR20J 47 kΩ
R5	7010003620	Resistor	ELR20J 47 kΩ
R6	7010003530	Resistor	ELR20J 10 kΩ
R7	7010003280	Resistor	ELR20J 100 Ω
R8	7010003620	Resistor	ELR20J 47 kΩ
R9	7410000180	Resistor Array	RMX- 8 103K
R10	7010003530	Resistor	ELR20J 10 kΩ
R11	7010003530	Resistor	ELR20J 10 kΩ
R12	7010003530	Resistor	ELR20J 10 kΩ
R14	7010003660	Resistor	ELR20J 100 kΩ
R15	7010003400	Resistor	ELR20J 1 kΩ
R16	7010003460	Resistor	ELR20J 3.3 kΩ
R17	7010003530	Resistor	ELR20J 10 kΩ
R18	7010003440	Resistor	ELR20J 2.2 kΩ
R19	7010003530	Resistor	ELR20J 10 kΩ
R20	7010003700	Resistor	ELR20J 220 kΩ
R21	7310001850	Trimmer	RH0421CS4J08A (473)
R22	7010004340	Resistor	R20J 15 kΩ
R23	7310001850	Trimmer	RH0421CS4J08A (473)
R24	7010003340	Resistor	ELR20J 330 Ω
R25	7010003440	Resistor	ELR20J 2.2 kΩ

[LOGIC UNIT]

REF. NO.	ORDER NO.	DESCRIPTION	
R26	7010003550	Resistor	ELR20J 15 kΩ
R27	7010003320	Resistor	ELR20J 220 Ω
R28	7010003550	Resistor	ELR20J 15 kΩ
R29	7010003600	Resistor	ELR20J 33 kΩ
R30	7010003620	Resistor	ELR20J 47 kΩ
R31	7010003530	Resistor	ELR20J 10 kΩ
R32	7010003620	Resistor	ELR20J 47 kΩ
R33	7310001710	Trimmer	RH0421C14J0KA (103)
R34	7010004450	Resistor	R20J 100 kΩ
R35	7010003340	Resistor	ELR20J 330 Ω
R36	7010003660	Resistor	ELR20J 100 kΩ
R37	7010003660	Resistor	ELR20J 100 kΩ
R38	7310001710	Trimmer	RH0421C14J0KA (103)
R39	7010003660	Resistor	ELR20J 100 kΩ
R40	7010003660	Resistor	ELR20J 100 kΩ
R41	7010004130	Resistor	R20J 330 Ω
R42	7010003660	Resistor	ELR20J 100 kΩ
R43	7010003670	Resistor	ELR20J 120 kΩ
R44	7010003490	Resistor	ELR20J 5.6 kΩ
R45	7310001710	Trimmer	RH0421C14J0KA (103)
R46	7010004410	Resistor	R20J 47 kΩ
R47	7010004320	Resistor	R20J 10 kΩ
R48	7010003600	Resistor	ELR20J 33 kΩ
C1	4010000810	Ceramic	DD105 CH 300J 50V
C2	4010000810	Ceramic	DD105 CH 300J 50V
C3	4040000190	Barrier Layer	UAT 05X 103K
C4	4040000190	Barrier Layer	UAT 05X 103K
C5	4040000190	Barrier Layer	UAT 05X 103K
C6	4040000190	Barrier Layer	UAT 05X 103K
C7	4040000190	Barrier Layer	UAT 05X 103K
C8	4510001300	Electrolytic	50 RC2 3.3 μF
C9	4040000260	Barrier Layer	UZE 08X 104M
C10	4040000190	Barrier Layer	UAT 05X 103K
C11	4040000260	Barrier Layer	UZE 08X 104M
C12	4040000260	Barrier Layer	UZE 08X 104M
C13	4040000190	Barrier Layer	UAT 05X 103K
C14	4040000190	Barrier Layer	UAT 05X 103K
C15	4310000060	Mylar	F2D 50V 223K
C16	4040000260	Barrier Layer	UZE 08X 104M
C17	4510003160	Electrolytic	16 RC2 22 μF (D=4.0)
C18	4510001240	Electrolytic	25 RC2 47 μF
C19	4040000260	Barrier Layer	UZE 08X 104M
C20	4310000010	Mylar	F2D 50V 102K
C21	4040000260	Barrier Layer	UZE 08X 104M
C22	4510001280	Electrolytic	50 RC2 1 μF
C23	4040000260	Barrier Layer	UZE 08X 104M
C24	4510003760	Electrolytic	16 RC2 100 μF
C25	4040000260	Barrier Layer	UZE 08X 104M
C26	4040000260	Barrier Layer	UZE 08X 104M
C27	4040000260	Barrier Layer	UZE 08X 104M
C28	4510003160	Electrolytic	16 RC2 22 μF (D=4.0)
C29	4510001280	Electrolytic	50 RC2 1 μF
C30	4510001280	Electrolytic	50 RC2 1 μF
C31	4040000260	Barrier Layer	UZE 08X 104M
C32	4040000260	Barrier Layer	UZE 08X 104M
C33	4550002430	Tantalum	DN 1V R33M
C34	4550000320	Tantalum	DN 1V 0R1M
C35	4510001210	Electrolytic	10 RC2 100 μF
C36	4510001280	Electrolytic	50 RC2 1 μF
DS1	5040000810	LED	SLN-210VC
S1	2260000080	Switch	SKHHAM024A
BT1	3020000070	Lithium Battery	BR2032-1HF
EP1	0910020193	P.C. Board	B 1835C (LOGIC)

[RX UNIT]

[RX UNIT]

REF. NO.	ORDER NO.	DESCRIPTION	
IC1	1110000630	IC	MC3357P
IC2	1110000580	IC	BA4558
IC3	1130002960	IC	TC9181P
IC4	1130003500	IC	TD6128P
IC5	1110001000	IC	μPC1651G
IC6	1130001830	IC	MN6520
IC7	1130000180	IC	TC4094BP
IC8	1180000470	IC	NJM7808A
IC9	1180000190	IC	NJM7805A
Q1	1580000050	FET	3SK121-Y
Q2	1580000050	FET	3SK121-Y
Q3	1530002210	Transistor	2SC3776-D
Q4	1530000150	Transistor	2SC2668-O
Q5	1530000110	Transistor	2SC2458-GR
Q6	1590000280	FET	2SJ105-Y
Q7	1530000960	Transistor	2SC3399
Q8	1530000960	Transistor	2SC3399
Q9	1530000660	Transistor	2SC1645B
Q10	1560000010	FET	2SK184-Y
Q11	1530000110	Transistor	2SC2458-GR
Q12	1530000110	Transistor	2SC2458-GR
D1	1790000250	Diode	1SS97
D2	1790000250	Diode	1SS97
D3	1730000120	Zener	RD6.2E B2
D4	1710000040	Diode	1S953
D5	1710000040	Diode	1S953
D7	1730000100	Zener	RD5.1E B2
FI1	2010000200	Filter	21M15B3 (FL-42) (USA-W, EUR-W, ITA-W)
	2010000650	Filter	21M 7B2 (FL-88) (USA-N, EUR-N, ITA-N)
FI2	2020000120	Ceramic	CFW455E (USA-W, EUR-W, ITA-W)
	2020000150	Ceramic	CFW455HT (USA-N, EUR-N, ITA-N)
X1	6050002000	Crystal	CR-70
X2	6070000010	Discriminator	CDB455C7A
X3	6050003110	Crystal	RF-4A3 FAC NKD (4.194304M)
L1	6110001620	Coil	LA-245
L2	6110001620	Coil	LA-245
L3	6170000230	Coil	LW-25
L4	6110001620	Coil	LA-245
L5	6110001620	Coil	LA-245
L6	6110001620	Coil	LA-245
L7	6110001540	Coil	LA-234
L8	6150002000	Coil	LS-264
L9	6150002000	Coil	LS-264
L10	6180000900	Coil	LAL 03NA 101K
L11	6180000770	Coil	LAL 03NA 1R0M
L12	6180001300	Coil	LAL 02NA 100K
R1	7010003620	Resistor	ELR20J 47 kΩ
R2	7010004070	Resistor	R20J 100 Ω
R3	7010003660	Resistor	ELR20J 100 kΩ
R4	7010003660	Resistor	ELR20J 100 kΩ
R5	7010003280	Resistor	ELR20J 100 Ω
R6	7010003650	Resistor	ELR20J 82 kΩ
R7	7010003280	Resistor	ELR20J 100 Ω
R8	7010003440	Resistor	ELR20J 2.2 kΩ
R9	7010003620	Resistor	ELR20J 47 kΩ
R10	7010003360	Resistor	ELR20J 470 Ω
R11	7010003580	Resistor	ELR20J 22 kΩ
R12	7010003480	Resistor	ELR20J 4.7 kΩ

REF. NO.	ORDER NO.	DESCRIPTION	
R13	7010003340	Resistor	ELR20J 330 Ω
R14	7010004070	Resistor	R20J 100 Ω
R15	7010004350	Resistor	R20J 18 kΩ
R16	7010004070	Resistor	R20J 100 Ω
R17	7010003280	Resistor	ELR20J 100 Ω
R18	7010003420	Resistor	ELR20J 1.5 kΩ (USA-W, EUR-W, ITA-W)
	7010003440	Resistor	ELR20J 2.2 kΩ (USA-N, EUR-N, ITA-N)
R19	7010004420	Resistor	R20J 56 kΩ
R20	7010004210	Resistor	R20J 1.5 kΩ
R21	7010003480	Resistor	ELR20J 4.7 kΩ
R22	7010003400	Resistor	ELR20J 1 kΩ
R23	7010003420	Resistor	ELR20J 1.5 kΩ (USA-W, EUR-W, ITA-W)
	7010003440	Resistor	ELR20J 2.2 kΩ (USA-N, EUR-N, ITA-N)
R24	7010003620	Resistor	ELR20J 47 kΩ
R25	7010004210	Resistor	R20J 1.5 kΩ
R26	7010003360	Resistor	ELR20J 470 Ω
R27	7010003720	Resistor	ELR20J 330 kΩ (USA-W, EUR-W, ITA-W)
	7010003750	Resistor	ELR20J 560 kΩ (USA-N, EUR-N, ITA-N)
R28	7010003460	Resistor	ELR20J 3.3 kΩ
R29	7010004230	Resistor	R20J 2.2 kΩ
R30	7010003620	Resistor	ELR20J 47 kΩ
R32	7010004270	Resistor	R20J 4.7 kΩ
R33	7010003440	Resistor	ELR20J 2.2 kΩ
R34	7010003400	Resistor	ELR20J 1 kΩ
R35	7010003370	Resistor	ELR20J 560 Ω
R36	7010003280	Resistor	ELR20J 100 Ω
R37	7010004210	Resistor	R20J 1.5 kΩ
R38	7010004210	Resistor	R20J 1.5 kΩ
R39	7010003400	Resistor	ELR20J 1 kΩ
R40	7010003940	Resistor	R20J 8.2 Ω
R41	7010004090	Resistor	R20J 150 Ω
R42	7010003940	Resistor	R20J 8.2 Ω
R43	7010003150	Resistor	ELR20J 8.2 Ω
R44	7010003300	Resistor	ELR20J 150 Ω
R45	7010003150	Resistor	ELR20J 8.2 Ω
R46	7010003330	Resistor	ELR20J 270 Ω
R47	7010003980	Resistor	R20J 18 Ω
R48	7010003330	Resistor	ELR20J 270 Ω
R49	7010003300	Resistor	ELR20J 150 Ω
R50	7010003150	Resistor	ELR20J 8.2 Ω
R51	7010003300	Resistor	ELR20J 150 Ω
R52	7010003150	Resistor	ELR20J 8.2 Ω
R53	7010003630	Resistor	ELR20J 56 kΩ
R54	7010003630	Resistor	ELR20J 56 kΩ
R55	7010003720	Resistor	ELR20J 330 kΩ
R56	7010003480	Resistor	ELR20J 4.7 Ω
R57	7010003280	Resistor	ELR20J 100 Ω
R58	7010003550	Resistor	ELR20J 15 kΩ
R59	7010003530	Resistor	ELR20J 10 kΩ
R60	7010003440	Resistor	ELR20J 2.2 kΩ
R61	7010003740	Resistor	ELR20J 470 kΩ
R62	7010003530	Resistor	ELR20J 10 kΩ
R63	7010003530	Resistor	ELR20J 10 kΩ
R64	7010003360	Resistor	ELR20J 470 Ω
R65	7010003580	Resistor	ELR20J 22 kΩ
R66	7010003510	Resistor	ELR20J 68 kΩ
R67	7010003790	Resistor	ELR20J 1.2 MΩ
R68	7010003790	Resistor	ELR20J 1.2 MΩ
R69	7010003280	Resistor	ELR20J 100 Ω
R70	7010003510	Resistor	ELR20J 6.8 kΩ
R71	7010003510	Resistor	ELR20J 6.8 kΩ
R72	7010003450	Resistor	ELR20J 2.7 kΩ
R73	7010003530	Resistor	ELR20J 10 kΩ
R74	7010003620	Resistor	ELR20J 47 kΩ
R75	7010003600	Resistor	ELR20J 33 kΩ
R76	7010003610	Resistor	ELR20J 39 kΩ
R77	7010004190	Resistor	R20J 1 kΩ
R78	7010004410	Resistor	R20J 47 kΩ

[RX UNIT]

REF. NO.	ORDER NO.	DESCRIPTION	
C1	401000050	Ceramic	DD104 SL 030C 50V
C2	4610000110	Trimmer	CV05C1201
C4	401000020	Ceramic	DD104 SL 010C 50V
C5	401000020	Ceramic	DD104 SL 010C 50V
C6	4610000110	Trimmer	CV05C1201
C8	401000020	Ceramic	DD104 SL 010C 50V
C9	401000050	Ceramic	DD104 B 102K 50V
C10	4010000460	Ceramic	DD104 B 471K 50V
C11	4010000500	Ceramic	DD104 B 102K 50V
C12	4010000460	Ceramic	DD104 B 471K 50V
C13	4010000500	Ceramic	DD104 B 102K 50V
C14	401000050	Ceramic	DD104 SL 030C 50V
C15	4610000110	Trimmer	CV05C1201
C17	401000020	Ceramic	DD104 SL 010C 50V
C18	401000020	Ceramic	DD104 SL 010C 50V
C19	4610000110	Trimmer	CV05C1201
C21	401000020	Ceramic	DD104 SL 010C 50V
C22	401000020	Ceramic	DD104 SL 010C 50V
C23	4610000110	Trimmer	CV05C1201
C25	401000050	Ceramic	DD104 SL 030C 50V
C26	4010000460	Ceramic	DD104 B 471K 50V
C27	4010000500	Ceramic	DD104 B 102K 50V
C29	4010000260	Ceramic	DD104 SL 470J 50V
C30	4010000460	Ceramic	DD104 B 471K 50V
C31	4010000500	Ceramic	DD104 B 102K 50V
C32	4010000330	Ceramic	DD105 SL 101J 50V
C33	4010000090	Ceramic	DD104 SL 070D 50V
	4010000150	Ceramic	DD104 SL 150J 50V
		(USA-N, EUR-N)	
C34	4010000340	Ceramic	DD105 SL 121J 50V
C35	4010000300	Ceramic	DD104 SL 680J 50V
C36	4010000460	Ceramic	DD104 B 471K 50V
C37	4010000500	Ceramic	DD104 B 102K 50V
C38	4040000150	Barrier Layer	UAT 05X 472K
C39	4010000500	Ceramic	DD104 B 102K 50V
C40	4550002880	Tantalum	DN 1V 0R1K
C41	4010000500	Ceramic	DD104 B 102K 50V
C42	4010000340	Ceramic	DD105 SL 121J 50V
C43	4010000280	Ceramic	DD104 SL 560J 50V
C44	4010000070	Ceramic	DD104 SL 050C 50V
C45	4510001230	Electrolytic	25 RC2 4.7 μF
C46	4010000500	Ceramic	DD104 B 102K 50V
C47	4510001230	Electrolytic	25 RC2 4.7 μF
C48	4550002880	Tantalum	DN 1V 0R1K
C49	4040000260	Barrier Layer	UZE 08X 104M
C50	4010000320	Ceramic	DD104 SL 820J 50V
C51	4010000500	Ceramic	DD104 B 102K 50V
C52	4040000110	Barrier Layer	UAT 04X 222K
		(USA-W, EUR-W)	
	4040000170	Barrier Layer	UAT 05X 682K
		(USA-N, EUR-N)	
C53	4010000500	Ceramic	DD104 B 102K 50V
C54	4010000500	Ceramic	DD104 B 102K 50V
C55	4010000500	Ceramic	DD104 B 102K 50V
C56	4010000500	Ceramic	DD104 B 102K 50V
C57	4010000220	Ceramic	DD104 SL 330J 50V
C58	4040000190	Barrier Layer	UAT 05X 103K
C59	4010000500	Ceramic	DD104 B 102K 50V
C60	4550001040	Tantalum	DN 1C 3R3M
C62	4510001210	Electrolytic	10 RC2 100 μF
C63	4040000260	Barrier Layer	UZE 08X 104M
C64	4010000460	Ceramic	DD104 B 471K 50V
C65	4550002460	Tantalum	DN 1V 3R3M
C66	4040000260	Barrier Layer	UZE 08X 104M
C67	4010000460	Ceramic	DD104 B 471K 50V
C68	4510002270	Electrolytic	6.3 RC2 47 μF
C69	4040000260	Barrier Layer	UZE 08X 104M
C70	4510001220	Electrolytic	16 RC2 10 μF
C71	4010000460	Ceramic	DD104 B 471K 50V
C72	4510001220	Electrolytic	16 RC2 10 μF
C73	4010000500	Ceramic	DD104 B 102K 50V
C74	4010000500	Ceramic	DD104 B 102K 50V
C75	4010000500	Ceramic	DD104 B 102K 50V
C76	4010000500	Ceramic	DD104 B 102K 50V

[RX UNIT]

REF. NO.	ORDER NO.	DESCRIPTION	
C77	4010000330	Ceramic	DD105 SL 101J 50V
C78	4010000330	Ceramic	DD105 SL 101J 50V
C79	4010000180	Ceramic	DD104 SL 220J 50V
C80	4550000350	Tantalum	DN 1V 010M
C81	4010000460	Ceramic	DD104 B 471K 50V
C82	4010000180	Ceramic	DD104 SL 220J 50V
C83	4010000240	Ceramic	DD104 SL 390J 50V
C84	4010000460	Ceramic	DD104 B 471K 50V
C85	4510001230	Electrolytic	25 RC2 4.7 μF
C86	4310000200	Mylar	F2D 50V 153K
C87	4310000170	Mylar	F2D 50V 682K
C88	4510001280	Electrolytic	50 RC2 1 μF
C89	4510001220	Electrolytic	16 RC2 10 μF
C90	4040000260	Barrier Layer	UZE 08X 104M
C91	4040000260	Barrier Layer	UZE 08X 104M
C92	4010000160	Ceramic	DD104 SL 180J 50V
C93	4010000160	Ceramic	DD104 SL 180J 50V
C94	4510002270	Electrolytic	6.3 RC2 47 μF
C95	4010000500	Ceramic	DD104 B 102K 50V
C96	4040000190	Barrier Layer	UAT 05X 103K
C97	4040000190	Barrier Layer	UAT 05X 103K
C98	4040000190	Barrier Layer	UAT 05X 103K
C99	4040000190	Barrier Layer	UAT 05X 103K
C100	4040000130	Barrier Layer	UAT 05X 332K
C101	4510002010	Electrolytic	50 RC2 0.33 μF
C102	4510001270	Electrolytic	50 RC2 0.47 μF
C103	4510001270	Electrolytic	50 RC2 0.47 μF
C104	4510001270	Electrolytic	50 RC2 0.47 μF
C105	4040000260	Barrier Layer	UZE 08X 104M
C106	4550000350	Tantalum	DN 1V 010M
C107	4550000340	Tantalum	DN 1C 100M
C108	4550000350	Tantalum	DN 1V 010M
C109	4550000340	Tantalum	DN 1C 100M
C110	4550002880	Tantalum	DN 1V 0R1K
EP1	0910030381	P.C. Board	B 3041A (RX)

[R-VCO UNIT]

REF. NO.	ORDER NO.	DESCRIPTION	
Q1	1560000130	FET	2SK125
Q2	1530000520	Transistor	2SC2026
D1	1720000060	Varicap	1SV50 (1) E
D2	1720000060	Varicap	1SV50 (1) E
D3	1720000060	Varicap	1SV50 (1) E
D4	1720000060	Varicap	1SV50 (1) E
D5	1720000060	Varicap	1SV50 (1) E
L1	6180000860	Coil	LAL 03NA 5R6K
L2	6180000800	Coil	LAL 03NA 1R8M
L4	6110001570	Coil	LA-237
L5	6180000830	Coil	LAL 03NA 3R3K
L6	6180000830	Coil	LAL 03NA 3R3K
L7	6180000830	Coil	LAL 03NA 3R3K
R1	7010003760	Resistor	ELR20J 680 kΩ
R2	7010003620	Resistor	ELR20J 47 kΩ
R3	7010003480	Resistor	ELR20J 4.7 kΩ
R4	7010003720	Resistor	ELR20J 330 kΩ
R5	7010003160	Resistor	ELR20J 10 Ω
R6	7010003400	Resistor	ELR20J 1 kΩ
R7	7010003480	Resistor	ELR20J 4.7 kΩ

[R-VCO UNIT]

REF. NO.	ORDER NO.	DESCRIPTION	
R8	7010003490	Resistor	ELR20J 5.6 kΩ
R9	7010003200	Resistor	ELR20J 22 Ω
C1	4610000120	Trimmer	CV05D2001
C2	4010000060	Ceramic	DD104 SL 040C 50V
C3	4010000060	Ceramic	DD104 SL 040C 50V
C4	4010000050	Ceramic	DD104 SL 030C 50V
C5	4510001550	Electrolytic	16 RC3 10 μF
C6	4010000500	Ceramic	DD104 B 102K 50V
C7	4010000500	Ceramic	DD104 B 102K 50V
C8	4510002280	Electrolytic	16 RC3 22 μF
C9	4010000050	Ceramic	DD104 SL 030C 50V
C10	4010000500	Ceramic	DD104 B 102K 50V
C11	4010000500	Ceramic	DD104 B 102K 50V
C12	4010000500	Ceramic	DD104 B 102K 50V
C13	4010000070	Ceramic	DD104 SL 050C 50V
EP1	0910011843	P.C. Board	B 1101C (R-VCO)

[R-DC-DC UNIT]

REF. NO.	ORDER NO.	DESCRIPTION	
IC1	1110000900	IC	TL499ACP
Q1	1530000660	Transistor	2SC1645B
D1	1730000520	Zener	RD20E B2
L1	6190000220	Coil	S0971136-101K
L2	6180001120	Coil	FL 5H 101K
R1	7010003400	Resistor	ELR20J 1 kΩ
R2	7030000300	Resistor	MCR10EZHZ 220 Ω (221)
R3	7030000300	Resistor	MCR10EZHZ 220 Ω (221)
R4	7030000300	Resistor	MCR10EZHZ 220 Ω (221)
R5	7030000610	Resistor	MCR10EZHZ 82 kΩ (823)
R6	7030000460	Resistor	MCR10EZHZ 4.7 kΩ (472)
R7	7030000340	Resistor	MCR10EZHZ 470 Ω (471)
C1	4030001090	Ceramic	GRM40 B 471K 50PT
C2	4510001120	Electrolytic	25 MS7 4R7 μF
C3	4510001120	Electrolytic	25 MS7 4R7 μF
C4	4510001120	Electrolytic	25 MS7 4R7 μF
C5	4510002020	Electrolytic	25 MS7 47 μF
C6	4550002880	Tantalum	DN 1V 0R1K
C7	4510002410	Electrolytic	6R3 MS7 100 μF (6.3X7)
C8	4510004400	Electrolytic	6R3 MS7 330 μF
C9	4510001100	Electrolytic	16 MS7 10 μF
EP1	0910016901	P.C. Board	B 1558A (R-DC-DC)

[TX UNIT]

REF. NO.	ORDER NO.	DESCRIPTION	
IC1	1110001000	IC	μPC1651G
IC2	1130002960	IC	TC9181P
IC3	1130003500	IC	TD6128P
IC4	1130000180	IC	TC4094BP
IC5	1130000180	IC	TC4094BP
IC6	1130000950	IC	S-7116A
IC7	1110000580	IC	BA4558
IC8	1180000190	IC	NJM7805A
IC9	1180000470	IC	NJM7808A
IC10	1110000580	IC	BA4558
Q2	1530001810	Transistor	2SC3355
Q3	1530000110	Transistor	2SC2458-GR
Q4	1560000010	FET	2SK184-Y
Q5	1530000591	Transistor	2SC2785 EL
Q6	1530000960	Transistor	2SC3399
Q7	1520000080	Transistor	2SB909M R
D2	1710000160	Diode	1SS133
D3	1710000160	Diode	1SS133
X1	6050005960	Crystal	CR-262
X2	6050003120	Crystal	RF-4A3 FAA NKD (3.579545M)
L1	6180000770	Coil	LAL 03NA 1R0M
L2	6110001550	Coil	LA-235
L3	6180001300	Coil	LAL 02NA 100K
L4	6910000670	Coil	BT01RN1-A61-001
L5	6180001510	Coil	LAL 02NA 101K
L6	6180002530	Coil	LAL 02NA R68K
L7	6180001740	Coil	LAL 02NA R82K
R2	7010003150	Resistor	ELR20J 8.2 Ω
R3	7010003300	Resistor	ELR20J 150 Ω
R4	7010003150	Resistor	ELR20J 8.2 Ω
R5	7010003330	Resistor	ELR20J 270 Ω
R6	7010003980	Resistor	R20J 18 Ω
R7	7010003330	Resistor	ELR20J 270 Ω
R8	7010003300	Resistor	ELR20J 150 Ω
R9	7010004110	Resistor	R20J 220 Ω
R10	7010003510	Resistor	ELR20J 6.8 kΩ
R11	7010003400	Resistor	ELR20J 1 kΩ
R12	7010003940	Resistor	R20J 8.2 Ω
R13	7010003300	Resistor	ELR20J 150 Ω
R14	7010003940	Resistor	R20J 8.2 Ω
R15	7010004270	Resistor	R20J 4.7 kΩ
R16	7010003440	Resistor	ELR20J 2.2 kΩ
R17	7010003280	Resistor	ELR20J 100 Ω
R18	7010003400	Resistor	ELR20J 1 kΩ
R19	7010003370	Resistor	ELR20J 560 Ω
R20	7010004210	Resistor	R20J 1.5 kΩ
R21	7010004210	Resistor	R20J 1.5 kΩ
R22	7010003400	Resistor	ELR20J 1 kΩ
R23	7410000540	Resistor Array	RKM5LW 222J
R24	7310000750	Trimmer	RH0651C14J2WA (103)
R25	7010003510	Resistor	ELR20J 6.8 kΩ
R26	7010003480	Resistor	ELR20J 4.7 kΩ
R27	7010003280	Resistor	ELR20J 100 Ω
R28	7010003530	Resistor	ELR20J 10 kΩ
R29	7010003440	Resistor	ELR20J 2.2 kΩ
R30	7010004110	Resistor	R20J 220 Ω
R31	7010004070	Resistor	R20J 100 Ω
R32	7310000780	Trimmer	RH0651CS4J25A (473)
R33	7010004500	Resistor	R20J 270 kΩ
R34	7010004320	Resistor	R20J 10 kΩ
R35	7010003400	Resistor	ELR20J 1 kΩ
R36	7010003400	Resistor	ELR20J 1 kΩ
R37	7010003480	Resistor	ELR20J 4.7 kΩ
R38	7010003280	Resistor	ELR20J 100 Ω

[TX UNIT]

REF. NO.	ORDER NO.	DESCRIPTION	
R41	7010003380	Resistor	ELR20J 680 Ω
R42	7010003520	Resistor	ELR20J 8.2 kΩ
R43	7010004320	Resistor	R20J 10 kΩ
R44	7010003590	Resistor	ELR20J 27 kΩ
R45	7010003480	Resistor	ELR20J 4.7 kΩ
R46	7010003480	Resistor	ELR20J 4.7 kΩ
R47	7010004330	Resistor	R20J 12 kΩ
R48	7010003550	Resistor	ELR20J 15 kΩ
R49	7010003590	Resistor	ELR20J 27 kΩ
R50	7010003320	Resistor	ELR20J 220 Ω
R51	7010003480	Resistor	ELR20J 4.7 kΩ
R52	7010003740	Resistor	ELR20J 470 kΩ
R53	7010004110	Resistor	R20J 220 Ω
R54	7310000740	Trimmer	RH0651CS3J2KA (472)
R55	7010003710	Resistor	ELR20J 270 kΩ
R56	7010003680	Resistor	ELR20J 150 kΩ
R57	7010004410	Resistor	R20J 47 kΩ
R58	7010003660	Resistor	ELR20J 100 kΩ
R59	7010004440	Resistor	R20J 82 kΩ
R60	7010003650	Resistor	ELR20J 82 kΩ
R61	7010004270	Resistor	R20J 4.7 kΩ
C2	4510001210	Electrolytic	10 RC2 100 μF
C3	4040000260	Barrier Layer	UZE 08X 104M
C4	4010000330	Ceramic	DD105 SL 101J 50V
C5	4010000330	Ceramic	DD105 SL 101J 50V
C6	4010000180	Ceramic	DD104 SL 220J 50V
C7	4550000350	Tantalum	DN 1V 010M
C8	4010000500	Ceramic	DD104 B 102K 50V
C9	4010000180	Ceramic	DD104 SL 220J 50V
C10	4010000460	Ceramic	DD104 B 471K 50V
C11	4010000500	Ceramic	DD104 B 102K 50V
C12	4010000180	Ceramic	DD104 SL 220J 50V
C13	4010000460	Ceramic	DD104 B 471K 50V
C14	4550002460	Tantalum	DN 1V 3R3M
C15	4040000260	Barrier Layer	UZE 08X 104M
C16	4510002270	Electrolytic	6.3 RC2 47 μF
C17	4010000460	Ceramic	DD104 B 471K 50V
C18	4040000260	Barrier Layer	UZE 08X 104M
C19	4510001220	Electrolytic	16 RC2 10 μF
C20	4010000460	Ceramic	DD104 B 471K 50V
C21	4510001220	Electrolytic	16 RC2 10 μF
C22	4010000500	Ceramic	DD104 B 102K 50V
C23	4010000500	Ceramic	DD104 B 102K 50V
C24	4010000500	Ceramic	DD104 B 102K 50V
C25	4010000500	Ceramic	DD104 B 102K 50V
C26	4040000260	Barrier Layer	UZE 08X 104M
C27	4510001240	Electrolytic	25 RC2 47 μF
C28	4040000150	Barrier Layer	UAT 05X 472K
C29	4040000150	Barrier Layer	UAT 05X 472K
C30	4010000560	Ceramic	DD106 F 103Z 50V
C31	4010000520	Ceramic	DD108 B 472K 50V
C32	4010000560	Ceramic	DD106 F 103Z 50V
C33	4010000380	Ceramic	DD107 SL 221J 50V
C34	4010000260	Ceramic	DD104 SL 470J 50V
C35	4010000460	Ceramic	DD104 B 471K 50V
C36	4010000160	Ceramic	DD104 SL 180J 50V
C37	4010000390	Ceramic	DD107 SL 271J 50V
C38	4010000330	Ceramic	DD105 SL 101J 50V
C39	4010000330	Ceramic	DD105 SL 101J 50V
C40	4510001220	Electrolytic	16 RC2 10 μF
C41	4010000820	Ceramic	DD105 CH 330J 50V
C42	4010000820	Ceramic	DD105 CH 330J 50V
C43	4510001270	Electrolytic	50 RC2 0.47 μF
C44	4510001230	Electrolytic	25 RC2 4.7 μF
C46	4510002420	Electrolytic	16 RC2 22 μF
C47	4010000500	Ceramic	DD104 B 102K 50V
C50	4010000500	Ceramic	DD104 B 102K 50V
C51	4010000500	Ceramic	DD104 B 102K 50V
C53	4550002880	Tantalum	DN 1V 0R1K
C54	4510001290	Electrolytic	50 RC2 2.2 μF
C55	4510001290	Electrolytic	50 RC2 2.2 μF
C56	4010000500	Ceramic	DD104 B 102K 50V
C57	4010000500	Ceramic	DD104 B 102K 50V

[TX UNIT]

REF. NO.	ORDER NO.	DESCRIPTION	
C58	4510002420	Electrolytic	16 RC2 22 μF
C59	4010000500	Ceramic	DD104 B 102K 50V
C61	4310000050	Mylar	F2D 50V 222K
C62	4010000340	Ceramic	DD105 SL 121J 50V
C63	4510001290	Electrolytic	50 RC2 2.2 μF
C64	4010000500	Ceramic	DD104 B 102K 50V
C65	4550000350	Tantalum	DN 1V 010M
C66	4550000340	Tantalum	DN 1C 100M
C67	4550000350	Tantalum	DN 1V 010M
C68	4550000340	Tantalum	DN 1C 100M
C69	4040000260	Barrier Layer	UZE 08X 104M
C70	4550002430	Tantalum	DN 1V R33M
EP1	0910030310	P.C. Board	B 3042 (R-DC-DC)

[T-VCO UNIT]

REF. NO.	ORDER NO.	DESCRIPTION	
Q1	1560000130	FET	2SK125
Q2	1530000520	Transistor	2SC2026
D1	1720000060	Varicap	1SV50 (1) E
D2	1720000060	Varicap	1SV50 (1) E
D3	1720000060	Varicap	1SV50 (1) E
D4	1720000060	Varicap	1SV50 (1) E
D5	1720000060	Varicap	1SV50 (1) E
L1	6180000860	Coil	LAL 03NA 5R6K
L2	6180000800	Coil	LAL 03NA 1R8M
L4	6110001570	Coil	LA-237
L5	6180000830	Coil	LAL 03NA 3R3K
L6	6180000830	Coil	LAL 03NA 3R3K
L7	6180000830	Coil	LAL 03NA 3R3K
R1	7010003760	Resistor	ELR20J 680 kΩ
R2	7010003620	Resistor	ELR20J 47 kΩ
R3	7010003480	Resistor	ELR20J 4.7 kΩ
R4	7010003720	Resistor	ELR20J 330 kΩ
R5	7010003160	Resistor	ELR20J 10 Ω
R6	7010003400	Resistor	ELR20J 1 kΩ
R7	7010003480	Resistor	ELR20J 4.7 kΩ
R8	7010003490	Resistor	ELR20J 5.6 kΩ
R9	7010003200	Resistor	ELR20J 22 Ω
C1	4610000120	Trimmer	CV05D2001
C2	4010000060	Ceramic	DD104 SL 040C 50V
C3	4010000060	Ceramic	DD104 SL 040C 50V
C4	4010000050	Ceramic	DD104 SL 030C 50V
C5	4510001550	Electrolytic	16 RC3 10 μF
C6	4010000500	Ceramic	DD104 B 102K 50V
C7	4010000500	Ceramic	DD104 B 102K 50V
C8	4510002280	Electrolytic	16 RC3 22 μF
C9	4010000050	Ceramic	DD104 SL 030C 50V
C10	4010000500	Ceramic	DD104 B 102K 50V
C11	4010000500	Ceramic	DD104 B 102K 50V
C12	4010000500	Ceramic	DD104 B 102K 50V
C13	4010000070	Ceramic	DD104 SL 050C 50V
EP1	0910011843	P.C. Board	B 1101C (T-VCO)



[T-DC-DC UNIT]

REF. NO.	ORDER NO.	DESCRIPTION	
IC1	1110000900	IC	TL499ACP
Q1	1530000660	Transistor	2SC1645B
D1	1730000520	Zener	RD20E B2
L1	6190000220	Coil	S0971136-101K
L2	6180001120	Coil	FL 5H 101K
R1	7010003400	Resistor	ELR20J 1 kΩ
R2	7030000300	Resistor	MCR10EZHZ 220 Ω (221)
R3	7030000300	Resistor	MCR10EZHZ 220 Ω (221)
R4	7030000300	Resistor	MCR10EZHZ 220 Ω (221)
R5	7030000610	Resistor	MCR10EZHZ 82 kΩ (823)
R6	7030000460	Resistor	MCR10EZHZ 4.7 kΩ (472)
R7	7030000340	Resistor	MCR10EZHZ 470 Ω (471)
C1	4030001090	Ceramic	GRM40 B 471K 50PT
C2	4510001120	Electrolytic	25 MS7 4R7 μF
C3	4510001120	Electrolytic	25 MS7 4R7 μF
C4	4510001120	Electrolytic	25 MS7 4R7 μF
C5	4510002020	Electrolytic	25 MS7 47 μF
C6	4550000320	Tantalum	DN 1V 0R1M
C7	4510002410	Electrolytic	6R3 MS7 100 μF (6.3X7)
C8	4510004400	Electrolytic	6R3 MS7 330 μF
C9	4510001100	Electrolytic	16 MS7 10 μF
EP1	0910016901	P.C. Board	B 1558A (T-VCO)

[PA UNIT]

REF. NO.	ORDER NO.	DESCRIPTION	
R7	7010003990	Resistor	R20J 22 Ω
R8	7010004270	Resistor	R20J 4.7 kΩ
R9	7010004270	Resistor	R20J 4.7 kΩ
R10	7010003480	Resistor	ELR20J 4.7 kΩ
R11	7010004370	Resistor	R20J 22 kΩ
R12	7010003280	Resistor	ELR20J 100 Ω
R13	7010003550	Resistor	ELR20J 15 kΩ
R14	7010003430	Resistor	ELR20J 1.8 kΩ
R15	7310000740	Trimmer	RH0651CS3J2KA (472)
R16	7010003770	Resistor	ELR20J 820 kΩ
R17	7010003530	Resistor	ELR20J 10 kΩ
R18	7010004390	Resistor	R20J 33 kΩ
R19	7010003530	Resistor	ELR20J 10 kΩ
R20	7010004130	Resistor	R20J 330 Ω
C1	4010000260	Ceramic	DD104 SL 470J 50V
C2	4010000460	Ceramic	DD104 B 471K 50V
C3	4010000150	Ceramic	DD104 SL 150J 50V
C5	4510001220	Electrolytic	16 RC2 10 μF
C6	4010000500	Ceramic	DD104 B 102K 50V
C7	4010000460	Ceramic	DD104 B 471K 50V
C8	4550000260	Tantalum	DN 1V 100M
C9	4010000500	Ceramic	DD104 B 102K 50V
C10	4010000460	Ceramic	DD104 B 471K 50V
C11	4010000460	Ceramic	DD104 B 471K 50V
C12	4010000500	Ceramic	DD104 B 102K 50V
C13	4510001220	Electrolytic	16 RC2 10 μF
C14	4010000160	Ceramic	DD104 SL 180J 50V
C15	4010003780	Ceramic	DD06 SL 010C 500V
C16	4010003780	Ceramic	DD06 SL 010C 500V
C17	4010000160	Ceramic	DD104 SL 180J 50V
C18	4010004120	Ceramic	DD07 B 102K 500V
C19	4010003910	Ceramic	DD06 SL 220K 500V
C20	4010003830	Ceramic	DD06 SL 060D 500V
C21	4010003960	Ceramic	DD06 SL 390K 500V
C22	4010003820	Ceramic	DD06 SL 050C 500V
C23	4010003950	Ceramic	DD06 SL 330K 500V
C24	4010003850	Ceramic	DD06 SL 080D 500V
C25	4010003880	Ceramic	DD06 SL 150K 500V
C26	4010000500	Ceramic	DD104 B 102K 50V
C27	4010000500	Ceramic	DD104 B 102K 50V
C28	4010000500	Ceramic	DD104 B 102K 50V
C29	4510001220	Electrolytic	16 RC2 10 μF
C30	4010000500	Ceramic	DD104 B 102K 50V
C31	4010000500	Ceramic	DD104 B 102K 50V
C32	4040000260	Barrier Layer	UZE 08X 104M
C33	4010000260	Ceramic	DD104 SL 470J 50V
EP1	0910030301	P.C. Board	B 3040A (PA)
EP3	8950001760		ELECTRICAL TAPE NO. 1245 L=70

[PA UNIT]

REF. NO.	ORDER NO.	DESCRIPTION	
IC1	1150000930	IC	SC1131 (136.0-150.0MHz)
	1150000940	IC	SC1132 (150.0-174.0MHz)
IC2	1110000070	IC	μPC358C
Q1	1530000640	Transistor	2SC2407 (A)
Q2	1530000110	Transistor	2SC2458-GR
Q3	1520000220	Transistor	2SB1019-Y
D1	1710000160	Diode	1SS133
D2	1790000250	Diode	1SS97
D3	1790000250	Diode	1SS97
L1	6110001530	Coil	LA-233
L2	6110001680	Coil	LA-254
L3	6110001660	Coil	LA-252
L4	6110001730	Coil	LA-262
L5	6110001660	Coil	LA-252
L6	6110001660	Coil	LA-252
R1	7010003940	Resistor	R20J 8.2 Ω
R2	7010003300	Resistor	ELR20J 150 Ω
R3	7010003940	Resistor	R20J 8.2 Ω
R4	7010004190	Resistor	R20J 1 kΩ
R5	7010004070	Resistor	R20J 100 Ω
R6	7010003400	Resistor	ELR20J 1 kΩ

[DIN UNIT]

REF. NO.	ORDER NO.	DESCRIPTION	
EP1	0910019162	P.C. Board	B 1841B (DIN)

**[REG-A UNIT]**

REF. NO.	ORDER NO.	DESCRIPTION	
IC1	1110001040	IC	MB3752M-G
IC2	1180000060	IC	NJM78L05A
IC3	1110002000	IC	BA10393
Q1	1520000080	Transistor	2SB909M R
D1	1710000350	Diode	1N4002
D2	1710000140	Diode	U05G
D3	1710000350	Diode	1N4002
D4	1710000350	Diode	1N4002
D5	1710000350	Diode	1N4002
R1	7010003440	Resistor	ELR20J 2.2 k $\Omega$
R2	7010003440	Resistor	ELR20J 2.2 k $\Omega$
R3	7310000730	Trimmer	RH0651CN3J01A (332)
R4	7010004190	Resistor	R20J 1 k $\Omega$
R5	7010003240	Resistor	ELR20J 47 $\Omega$
R6	7100000160	Resistor	SRW2P 100 $\Omega$ (101)
R7	7310000800	Trimmer	RH0651CJ5J01A (224)
R8	7010003690	Resistor	ELR20J 180 k $\Omega$
R9	7010004320	Resistor	R20J 10 k $\Omega$
C1	4010000500	Ceramic	DD104 B 102K 50V
C2	4510002900	Electrolytic	25 SS 470 $\mu$ F
C3	4550002880	Tantalum	DN 1V 0R1K
C4	4550002430	Tantalum	DN 1V R33M
RL1	6330000710	Relay	G2R-117P-V-RP-US DC12V
RL2	6330000710	Relay	G2R-117P-V-RP-US DC12V
EP1	0910019154	P.C. Board	B 1836D (REG-A)

**[REG-B UNIT]**

REF. NO.	ORDER NO.	DESCRIPTION	
Q1	1520000100	Transistor	2SB863-O
Q2	1520000100	Transistor	2SB863-O
Q3	1540000200	Transistor	2SD1406 Y
D1	1790000130	Diode	S25VB20
R1	7010004070	Resistor	R20J 100 $\Omega$
R2	7010004150	Resistor	R20J 470 $\Omega$
R3	7100000190	Resistor	SRW3P 0R03 $\Omega$ (R03)
R4	7100000190	Resistor	SRW3P 0R03 $\Omega$ (R03)
R5	7100000190	Resistor	SRW3P 0R03 $\Omega$ (R03)
R6	7100000190	Resistor	SRW3P 0R03 $\Omega$ (R03)
C1	4010000530	Ceramic	DD112 B 103K 50V
C2	4010000530	Ceramic	DD112 B 103K 50V
C3	4010000530	Ceramic	DD112 B 103K 50V
C4	4010000530	Ceramic	DD112 B 103K 50V
S1	6910000030	Thermostat	OHD 50M
EP1	0910019114	P.C. Board	B 1837D (REG-B)

# SECTION 6 ADJUSTMENT PROCEDURES

## 6-1 PREPARATION BEFORE SERVICING

### REQUIRED TEST EQUIPMENT

EQUIPMENT	GRADE AND RANGE	EQUIPMENT	GRADE AND RANGE
DC backup battery	Output voltage : 10~13.8 V DC Current capacity : 10A or more	AC millivoltmeter	Measuring range : 10 mV~3 V
RF power meter (terminated type)	Measuring range : 1~50 W Frequency range : 130~200 MHz Impedance : 50 Ω SWR : Less than 1.2: 1	Audio generator	Frequency range : 200~3000 Hz Output level : 1~300 mV
Frequency counter	Frequency range : 0.1~200 MHz Frequency accuracy : ±1 ppm or better Sensitivity : 100 mV or better	Attenuator	Power attenuation : 40 or 50 dB Capacity : 60 W or more
Oscilloscope	Frequency range : DC~20 MHz Measuring range : 0.01~10 V	Distortion meter	Frequency range : 1 kHz±10 Hz Measuring range : 1~20 %
Standard signal generator (SSG)	Frequency range : 0.1~200 MHz Output level : -127~-17 dBm (0.1 μV~32 mV)	FM deviation meter	Frequency minimum : 200 MHz Measuring range : 0~±10 kHz
		DC voltmeter	Input impedance : 50 kΩ/DC or better

CW: Clockwise CCW: Counterclockwise

### CONNECTION

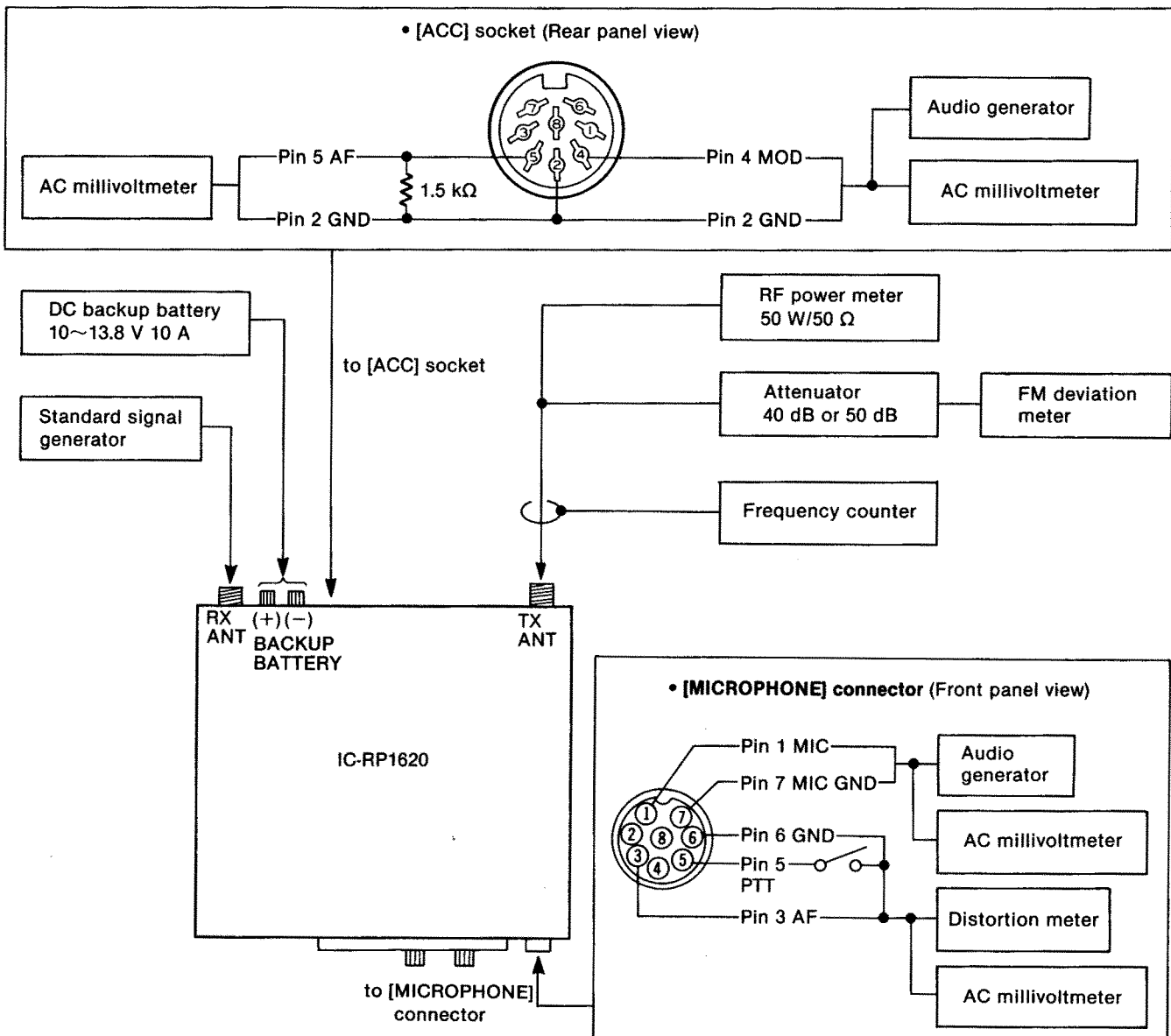

## 6-2 RX PLL ADJUSTMENT

ADJUSTMENT	ADJUSTMENT CONDITIONS	MEASUREMENT		VALUE	ADJUSTMENT POINT	
		UNIT	LOCATION		UNIT	ADJUST
LOCK VOLTAGE	1	RX (R-VCO)	Connect the DC voltmeter to R32. (Q11 Collector side)	1.5 V (Low-band version) 4.0 V (High-band version)	RX (R-VCO)	C1
	2					

### • Example of setting N-data for receiving

Receive frequency	: 136.000 MHz
1st IF frequency	: 21.800 MHz (fixed)
PLL reference frequency	: 0.005 MHz (5 kHz)

$$\begin{aligned}
 \text{N-data for receiving} &= \frac{\text{receive frequency} - 1\text{st IF frequency}}{\text{PLL reference frequency}} \\
 &= \frac{136.000 - 21.8}{0.005} \\
 &= 22840
 \end{aligned}$$

Receive frequency	: 150.000 MHz
1st IF frequency	: 21.800 MHz (fixed)
PLL reference frequency	: 0.0125 MHz (12.5 kHz)

$$\begin{aligned}
 \text{N-data for receiving} &= \frac{\text{receive frequency} - 1\text{st IF frequency}}{\text{PLL reference frequency}} \\
 &= \frac{150.000 - 21.8}{0.0125} \\
 &= 10256
 \end{aligned}$$

Set the dip switches (S1, S2) to the values equivalent to the obtained N-data.

Example of setting the dip switches.

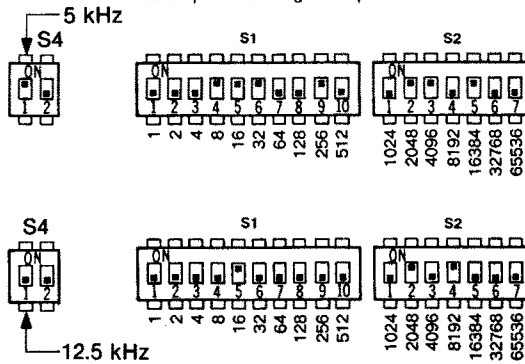

Dip switches	N-data value
S2-5	→ 16384
S2-3	→ 4096
S2-2	→ 2048
S1-9	→ 256
S1-6	→ 32
S1-5	→ 16
S1-4	→ 8 (+)
Total	22840

Dip switches	N-data value
S2-4	→ 8192
S2-2	→ 2048
S1-5	→ 16 (+)
Total	10256

### • LOGIC-A UNIT

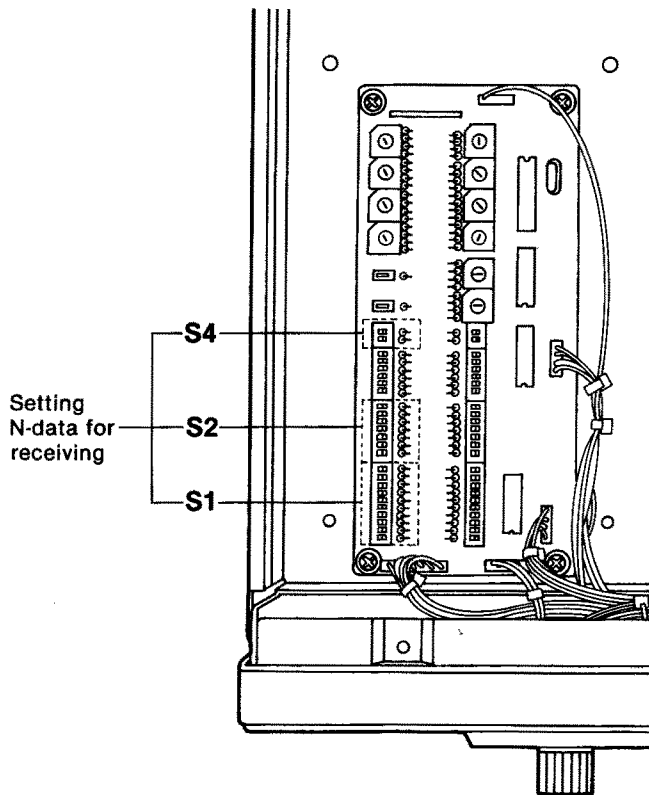

### • RX UNIT

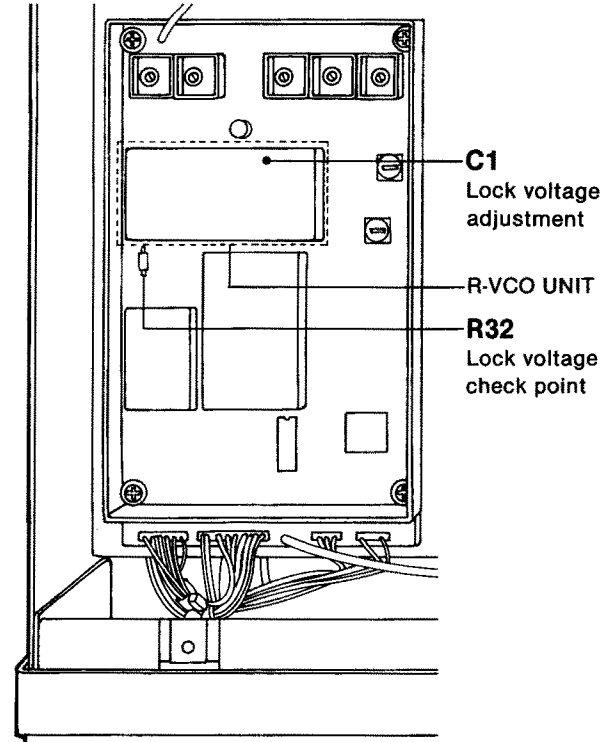

# 6-3 TX PLL ADJUSTMENT

ADJUSTMENT	ADJUSTMENT CONDITIONS	MEASUREMENT		VALUE	ADJUSTMENT POINT	
		UNIT	LOCATION		UNIT	ADJUST
LOCK VOLTAGE	1 <ul style="list-style-type: none"> <li>• Set the transmit frequency (See below): 150.000 MHz</li> <li>• Connect the RF power meter or a 50 Ω dummy load to the [TX ANT] connector.</li> <li>• Transmitting</li> </ul>	TX (T-VCO)	Connect the DC voltmeter to R15.	8.5 V	TX (T-VCO)	C1
REFERENCE FREQUENCY	1 <ul style="list-style-type: none"> <li>• Set the transmit frequency (See below): 150.000 MHz</li> <li>• Connect the RF power meter or a 50 Ω dummy load to the [TX ANT] connector.</li> <li>• Transmitting</li> </ul>	Rear panel	Loosely couple the frequency counter to the [TX ANT] connector.	150,000,000 Hz	TX	R24
	2	After adjustment, program the identification frequency.				

### • Example of setting N-data for transmitting

Transmit frequency : 150.000 MHz  
 PLL reference frequency : 0.005 MHz (5 kHz)

$$N\text{-data for transmitting} = \frac{\text{transmit frequency}}{\text{PLL reference frequency}} = \frac{150.000}{0.005} = 30000$$

Transmit frequency : 150.000 MHz  
 PLL reference frequency : 0.0125 MHz (12.5 kHz)

$$N\text{-data for transmitting} = \frac{\text{transmit frequency}}{\text{PLL reference frequency}} = \frac{150.000}{0.0125} = 12000$$

Set the dip switches (S9, S10) to the values equivalent to the obtained N-data.

Example of setting the dip switches.

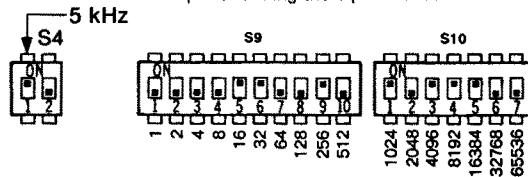

Dip switches	N-data value
S10-5	→ 16384
S10-4	→ 8192
S10-3	→ 4096
S10-1	→ 1024
S9-9	→ 256
S9-6	→ 32
S9-5	→ 16 (+)
<b>Total</b>	<b>30000</b>

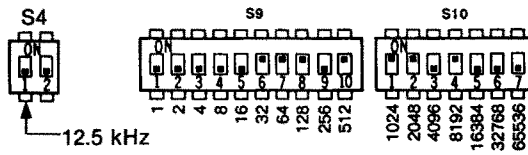

Dip switches	N-data value
S10-4	→ 8192
S10-2	→ 2048
S10-1	→ 1024
S9-10	→ 512
S9-8	→ 128
S9-7	→ 64
S9-6	→ 32 (+)
<b>Total</b>	<b>12000</b>

### • LOGIC-A UNIT

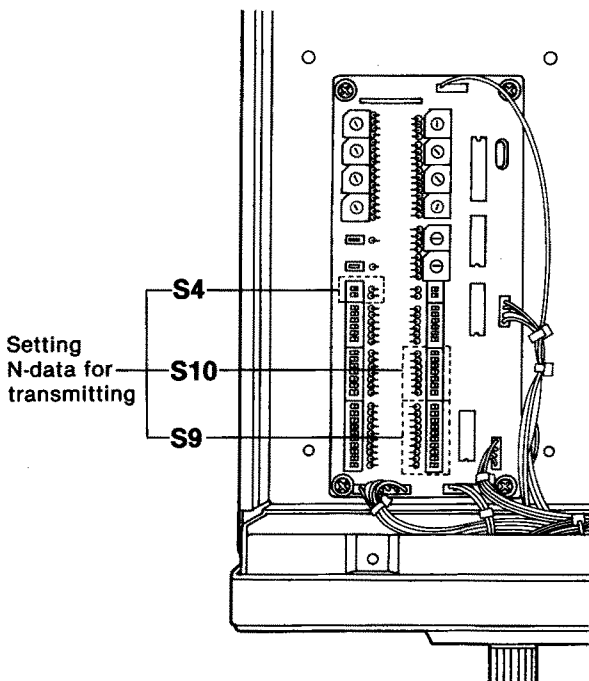

### • TX UNIT

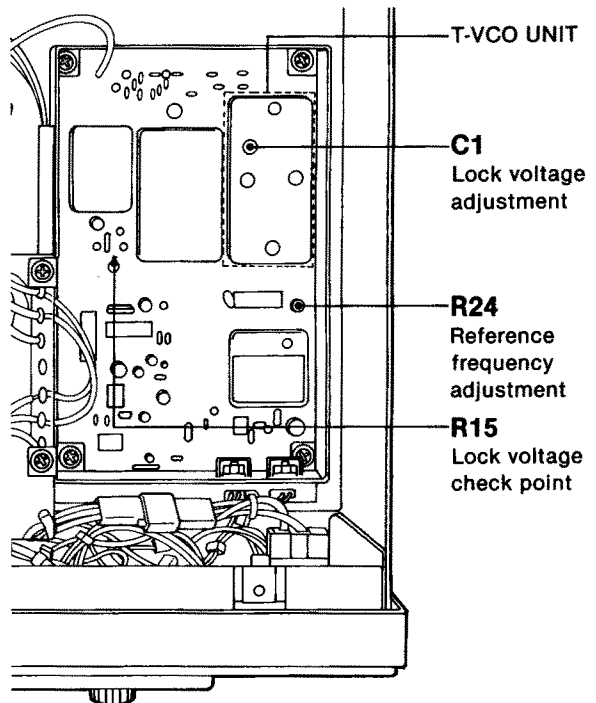

## 6-4 RECEIVER ADJUSTMENT

ADJUSTMENT	ADJUSTMENT CONDITIONS	MEASUREMENT		VALUE	ADJUSTMENT POINT	
		UNIT	LOCATION		UNIT	ADJUST
SENSITIVITY	1 <ul style="list-style-type: none"> <li>• [LOCAL INHIBIT] switch: ON</li> <li>• Connect the SSG to the [RX ANT] connector and set as:               <ul style="list-style-type: none"> <li>Level : 10 <math>\mu</math>V* (-87 dBm)</li> <li>Modulation: 1 kHz</li> <li>Deviation : <math>\pm</math>3.5 kHz (Wide version)</li> <li><math>\pm</math>1.75 kHz (Narrow version)</li> </ul> </li> <li>• Receiving</li> </ul>	RX	Connect the distortion meter to the [MICROPHONE] connector, pin 3 (AF) and 6 (GND) with an AC millivoltmeter.	Minimum distortion level	RX	Adjust in sequence C2, C6, C15, C19, C23, L8, L9

\* This output level of the standard signal generator (SSG) is indicated as SSG's open circuit.

### • RX UNIT

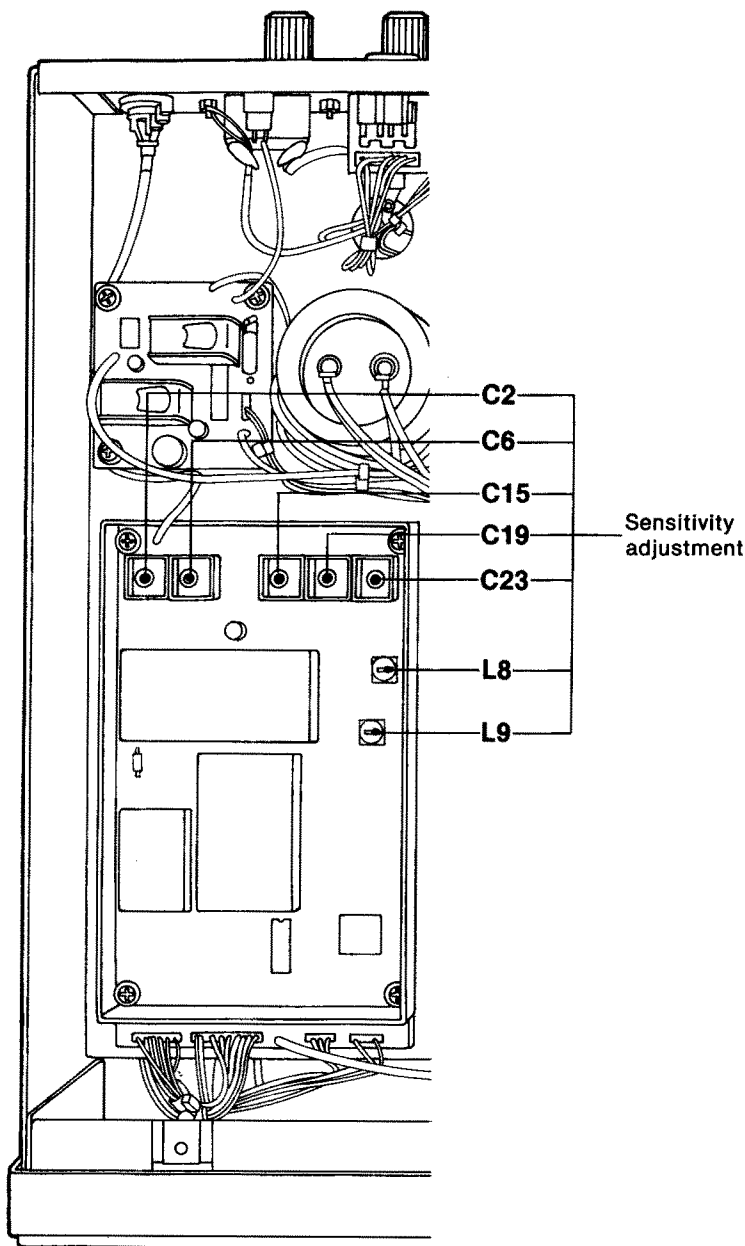

## 6-5 TRANSMITTER ADJUSTMENT

ADJUSTMENT	ADJUSTMENT CONDITIONS	MEASUREMENT		VALUE	ADJUSTMENT POINT				
		UNIT	LOCATION		UNIT	ADJUST			
DEVIATION (CTCSS TONE)	1	<ul style="list-style-type: none"> <li>• [LOCAL INHIBIT] switch: ON</li> <li>• Set the FM deviation meter as:                HPF : OFF                LPF : 20 kHz                De-emphasis: OFF                Detector : (P-P)/2</li> <li>• Transmitting                (Ground the [MICROPHONE]                connector (pin 5).)</li> </ul>	Rear panel	Connect the FM deviation meter to the [TX ANT] connector via the attenuator.					
	2	<ul style="list-style-type: none"> <li>• S5 (LOGIC-A UNIT) switch: push once</li> </ul>					0.8 kHz	TX	R32
	3	After adjustment, turn the [LOCAL INHIBIT] switch OFF, and push S5 again.							
DEVIATION (MICROPHONE)	1	<ul style="list-style-type: none"> <li>• [LOCAL INHIBIT] switch: ON</li> <li>• Connect the audio generator to the [MICROPHONE] connector and set as:                Level : 4 mV                Modulation : 1.0 kHz</li> <li>• Set the FM deviation meter as:                HPF : OFF                LPF : 20 kHz                De-emphasis: OFF                Detector : (P-P)/2</li> <li>• Transmitting</li> </ul>	Rear panel	Connect the FM deviation meter to the [TX ANT] connector via the attenuator.	4.2 kHz (Wide version) 2.1 kHz (Narrow version)	TX	R54		
	2	<ul style="list-style-type: none"> <li>• Set the audio generator as:                Level : 40 mV</li> </ul>						4.0~5.0 kHz (Wide version) 2.0~2.5 kHz (Narrow version)	Verify
	3	After adjustment, turn the [LOCAL INHIBIT] switch OFF.							
DEVIATION (REPEATER)	1	<ul style="list-style-type: none"> <li>• Connect the SSG to the [RX ANT] connector and set as:                Level : 1.0 mV* (-47 dBm)                Modulation : 1 kHz                Deviation : ±3.5 kHz                (Wide version)                ±1.75 kHz                (Narrow version)</li> <li>• Set the FM deviation meter as:                HPF : OFF                LPF : 20 kHz                De-emphasis: OFF                Detector : (P-P)/2</li> <li>• Transmitting</li> </ul>	Rear panel	Connect the FM deviation meter to the [TX ANT] connector via the attenuator.	3.5 kHz (Wide version) 1.75 kHz (Narrow version)	LOGIC	R33		
	2	<ul style="list-style-type: none"> <li>• Set the SSG as:                Level : 1.0 mV* (-47 dBm)                Modulation : 1 kHz                Deviation : ±5.0 kHz                (Wide version)                ±2.5 kHz                (Narrow version)</li> </ul>						3.5~5.0 kHz (Wide version) 1.75~2.5 kHz (Narrow version)	Verify

\*This output level of the standard signal generator (SSG) is indicated as SSG's open circuit.

• LOGIC-A UNIT

**S5** Deviation  
(CTCSS TONE)  
presetting

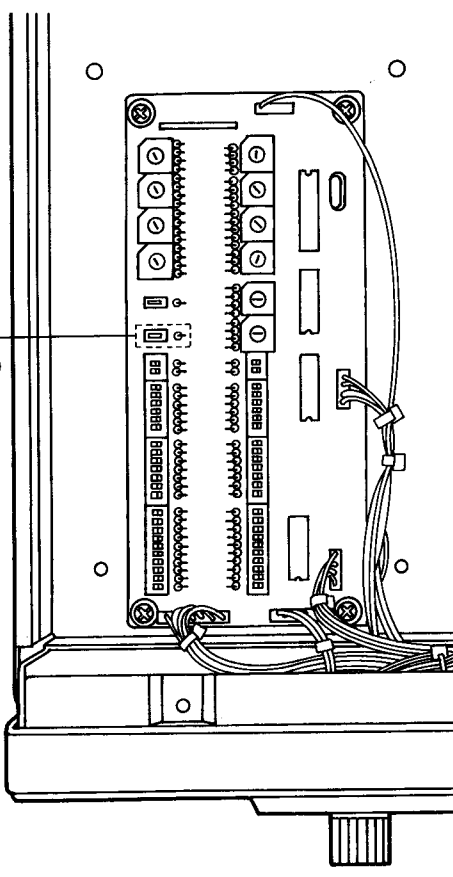

• LOGIC UNIT

**R33** Deviation  
(REPEATER)  
adjustment

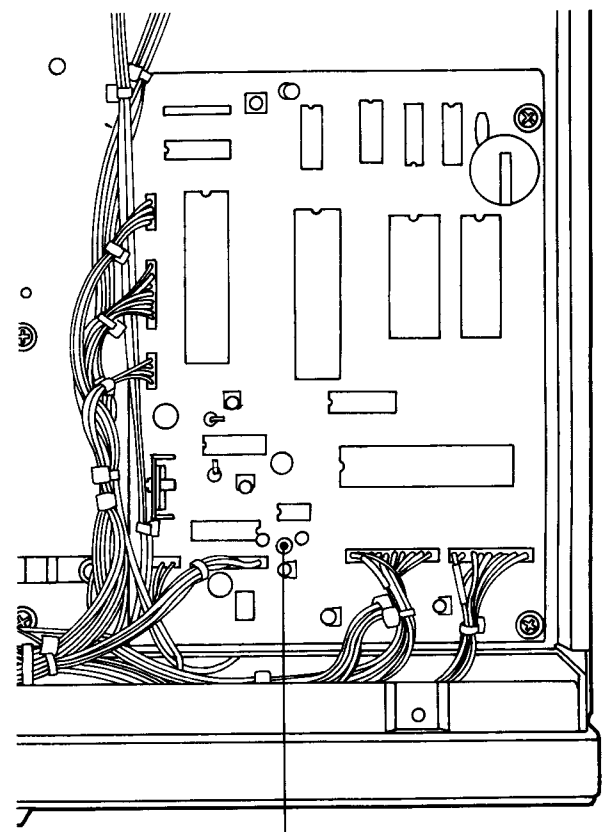

• TX UNIT

**R54** Deviation  
(MICROPHONE)  
adjustment

**R32** Deviation  
(CTCSS TONE)  
adjustment

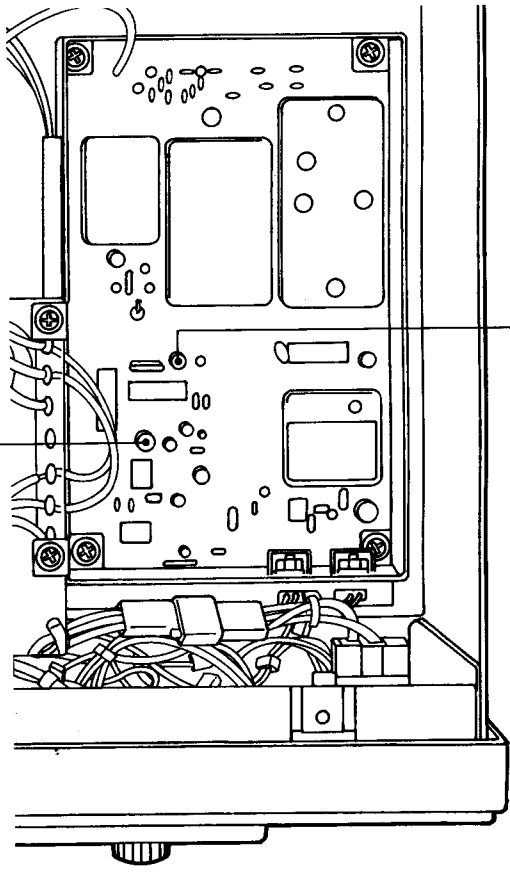



## TRANSMITTER ADJUSTMENT (CONTINUED)

ADJUSTMENT	ADJUSTMENT CONDITIONS	MEASUREMENT		VALUE	ADJUSTMENT POINT	
		UNIT	LOCATION		UNIT	ADJUST
DEVIATION (ID)	<ul style="list-style-type: none"> <li>• Connect W1 (LOGIC UNIT).</li> <li>• Connect the FM deviation meter to the [TX ANT] connector via the attenuator and set as:                HPF : OFF                LPF : 20 kHz                De-emphasis: OFF                Detector : (P-P)/2</li> <li>• Transmitting (Ground the [MICROPHONE] connector (pin 5).)</li> </ul>	LOGIC	Connect the frequency counter to R22.	800 Hz	LOGIC	R21
		Rear panel	FM deviation meter.	1 kHz		R23
	3	After adjustment, disconnect W1.				
DEVIATION (EXTERNAL)	<ul style="list-style-type: none"> <li>• Connect the SSG to the [RX ANT] connector and set as:                Level : 1.0 mV* (-47 dBm)                Modulation : 1 kHz                Deviation : ±3.5 kHz (Wide version)                                  ±1.75 kHz (Narrow version)</li> </ul>	Rear panel	Connect the AC millivoltmeter to the [ACC] socket, pin 5 (AF) and pin 2 (GND).	20 mV	LOGIC	R45
	<ul style="list-style-type: none"> <li>• Connect the audio generator to the [ACC] socket, pin 4 (MOD) and pin 2 (GND) and set as:                Level : 500 mV                Modulation : 1 kHz</li> <li>• Set the FM deviation meter as:                HPF : OFF                LPF : 20 kHz                De-emphasis: OFF                Detector : (P-P)/2</li> </ul>		Connect the FM deviation meter to the [TX ANT] connector via the attenuator.			3.5 kHz (Wide version) 1.75 kHz (Narrow version)

\* This output level of the standard signal generator (SSG) is indicated as SSG's open circuit.

### • LOGIC UNIT

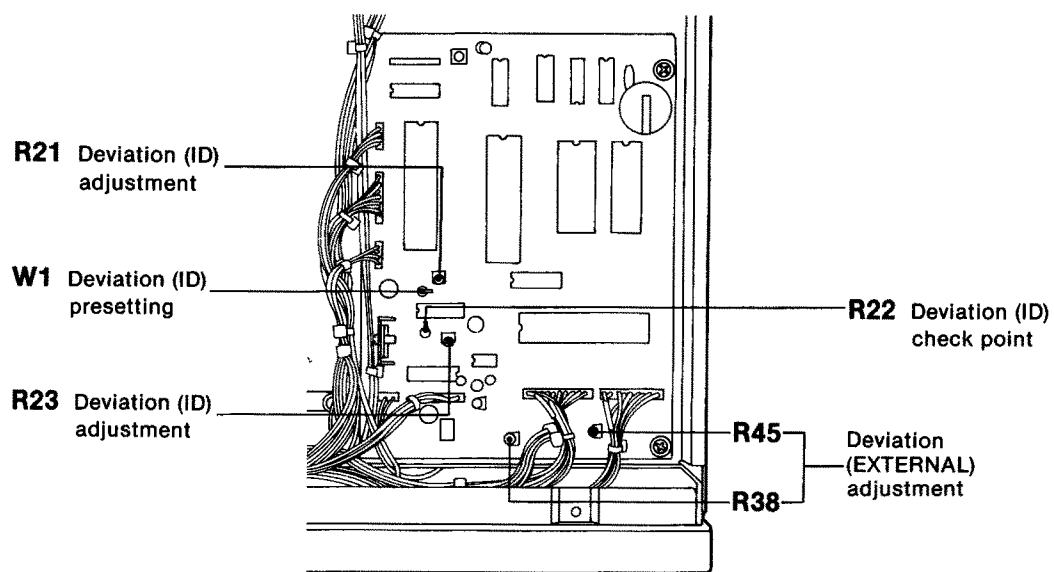

## TRANSMITTER ADJUSTMENT (CONTINUED)

ADJUSTMENT	ADJUSTMENT CONDITIONS	MEASUREMENT		VALUE	ADJUSTMENT POINT	
		UNIT	LOCATION		UNIT	ADJUST
OUTPUT POWER	1 <ul style="list-style-type: none"> <li>• [LOCAL INHIBIT] switch: ON</li> <li>• Transmitting (Ground the [MICROPHONE] connector (pin 5).)</li> </ul>	Rear panel	Connect the RF power meter to the [TX ANT] connector.	25 W	PA	R15
REGULATOR OUTPUT VOLTAGE	1 <ul style="list-style-type: none"> <li>• Apply AC voltage to the [AC] connector.</li> <li>• Remove W18 (EP3).</li> <li>• Transmitting</li> </ul>	REG-A	Connect the DC voltmeter to EP3, pin 3.	14 V	REG-A	R3
		2	Front panel	[POWER] indicator	Lights up in green.	Front panel
	3	After adjustment, disconnect AC voltage.				
	4 <ul style="list-style-type: none"> <li>• Apply DC voltage (10 V).</li> <li>• [DC RESET] switch: ON</li> </ul>	REG-A	Connect the DC voltmeter to EP3, pin 3.	0 V	REG-A	R7
	5 <ul style="list-style-type: none"> <li>• Apply DC voltage (12 V).</li> <li>• [DC RESET] switch: ON</li> </ul>			12 V		
	6	Front panel	[POWER] indicator	Lights up in red.	Front panel	Verify
	7	After adjustment, reconnect W18.				

### • PA AND REG-A UNITS

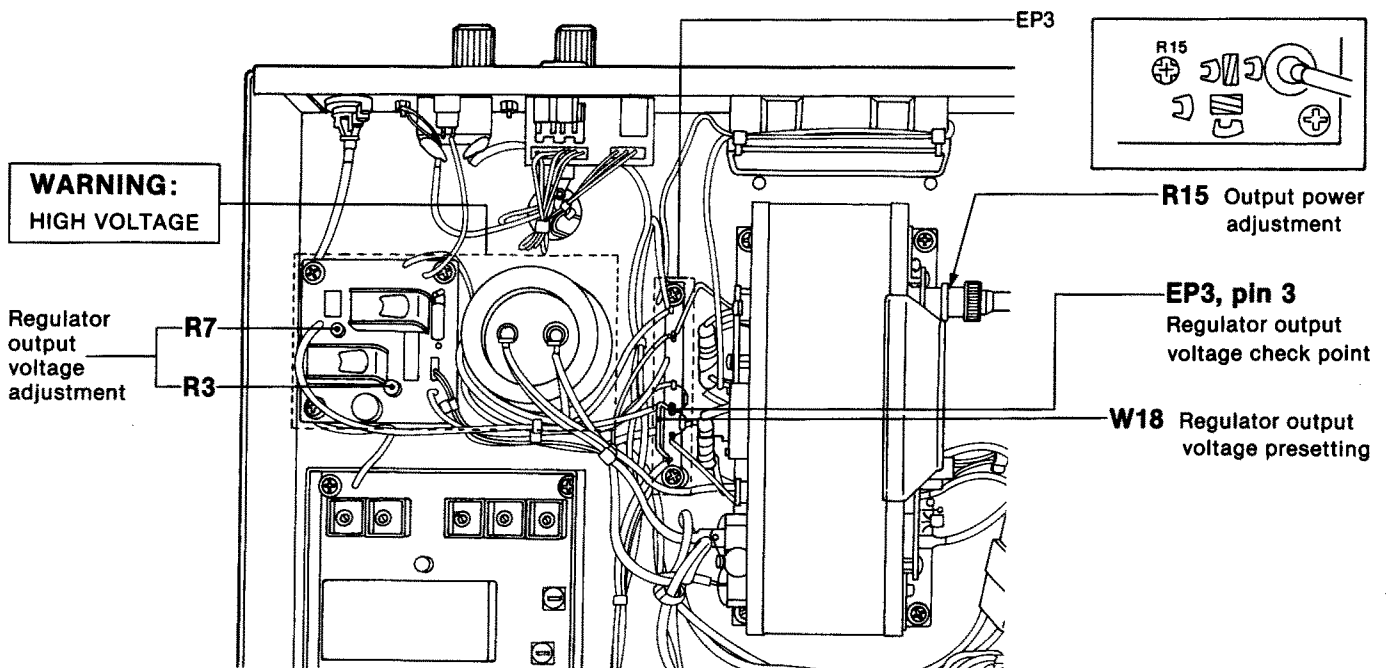

# SECTION 7 BOARD LAYOUTS

## 7-1 FRONT UNIT

### • MIC UNIT

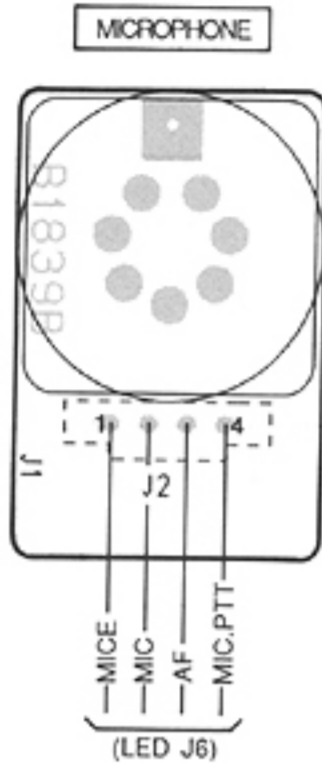

### • AF UNIT

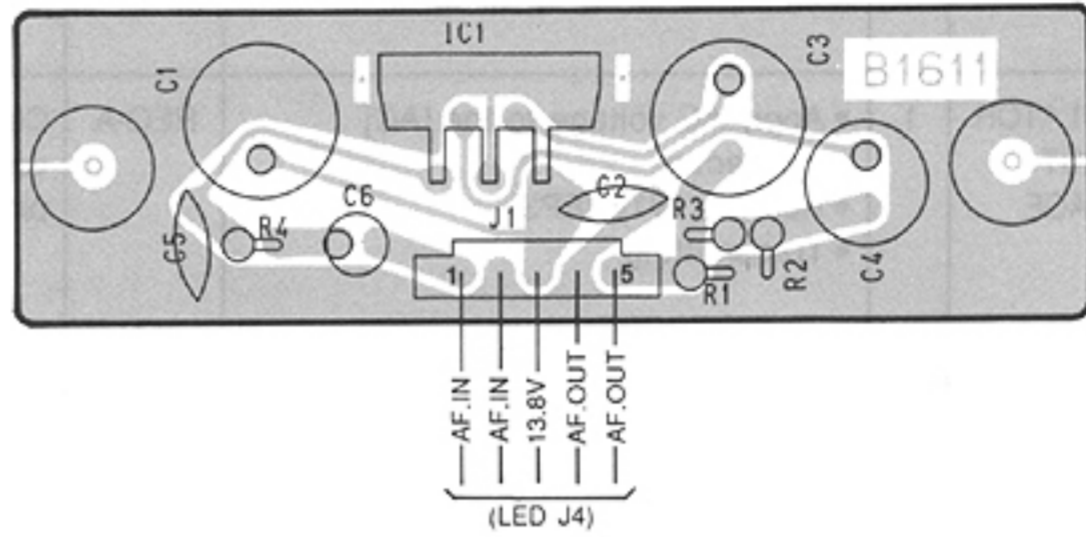

### • LED UNIT

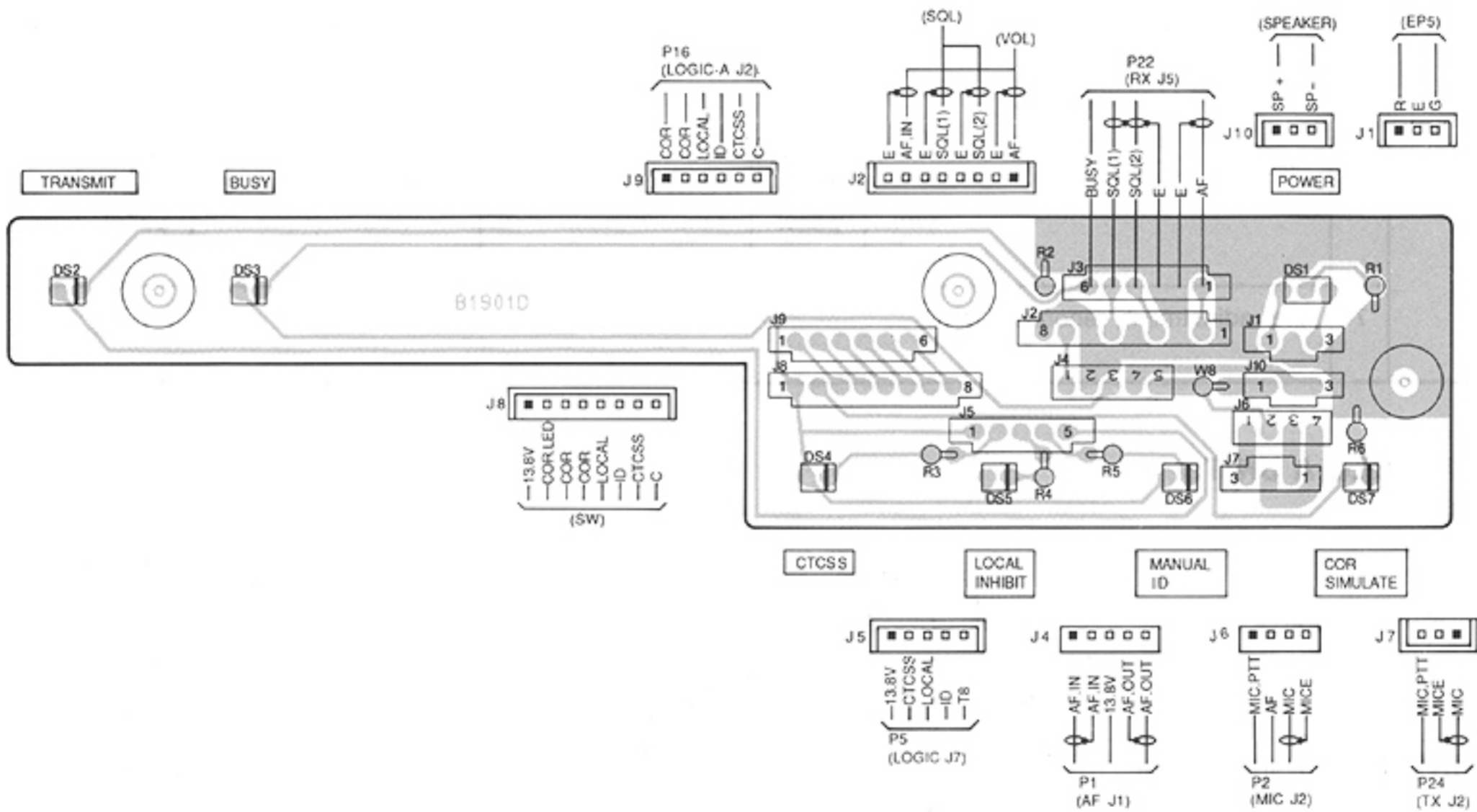

### • SW UNIT

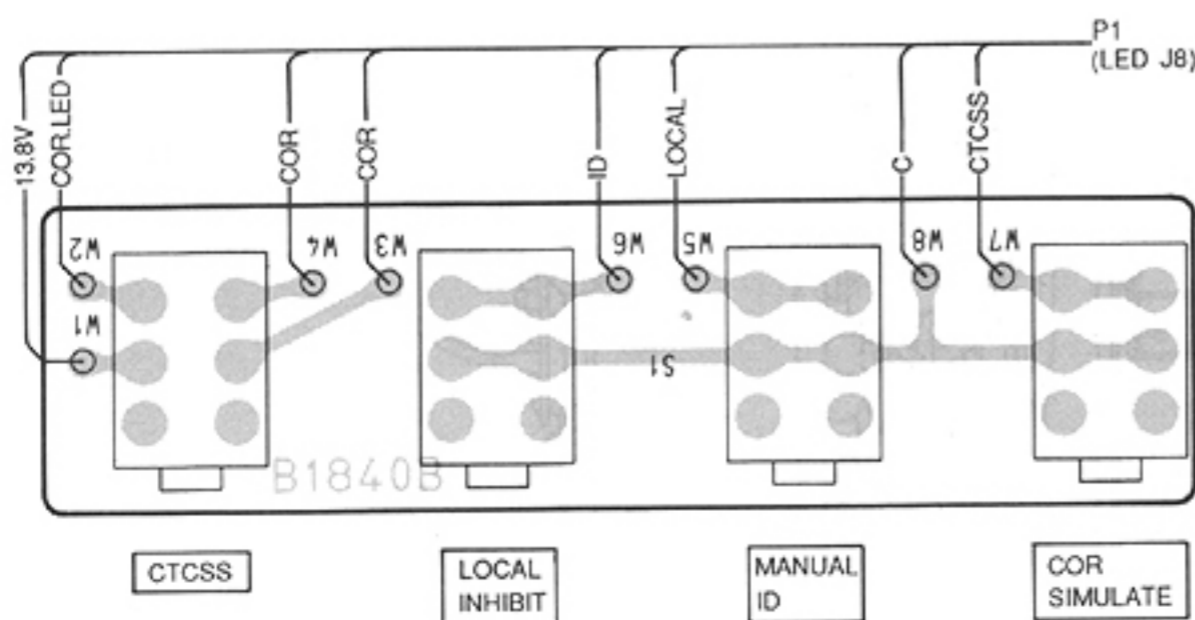

# 7-2 LOGIC-A UNIT

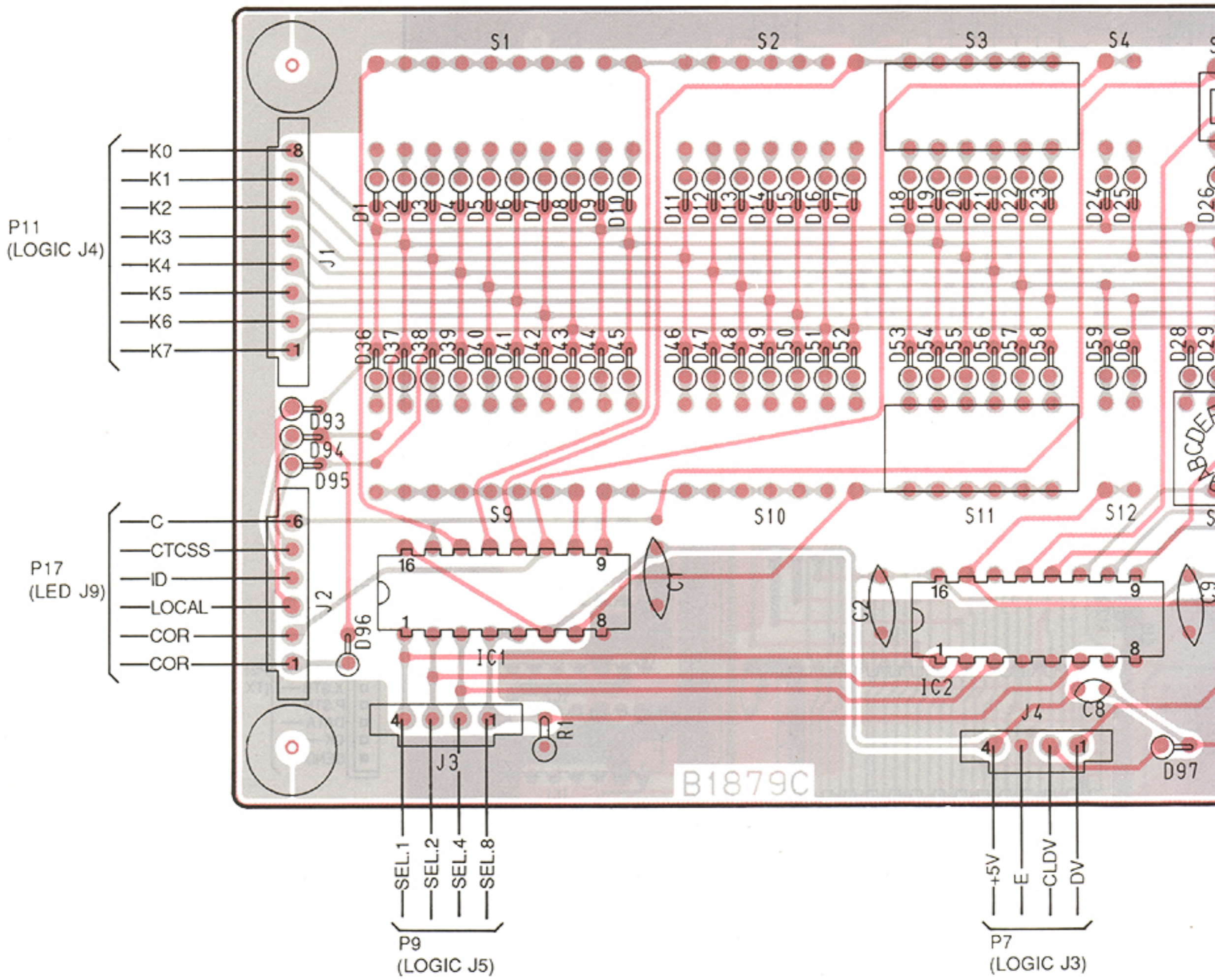

2SC1815-Y

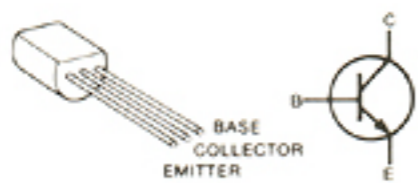

Q1

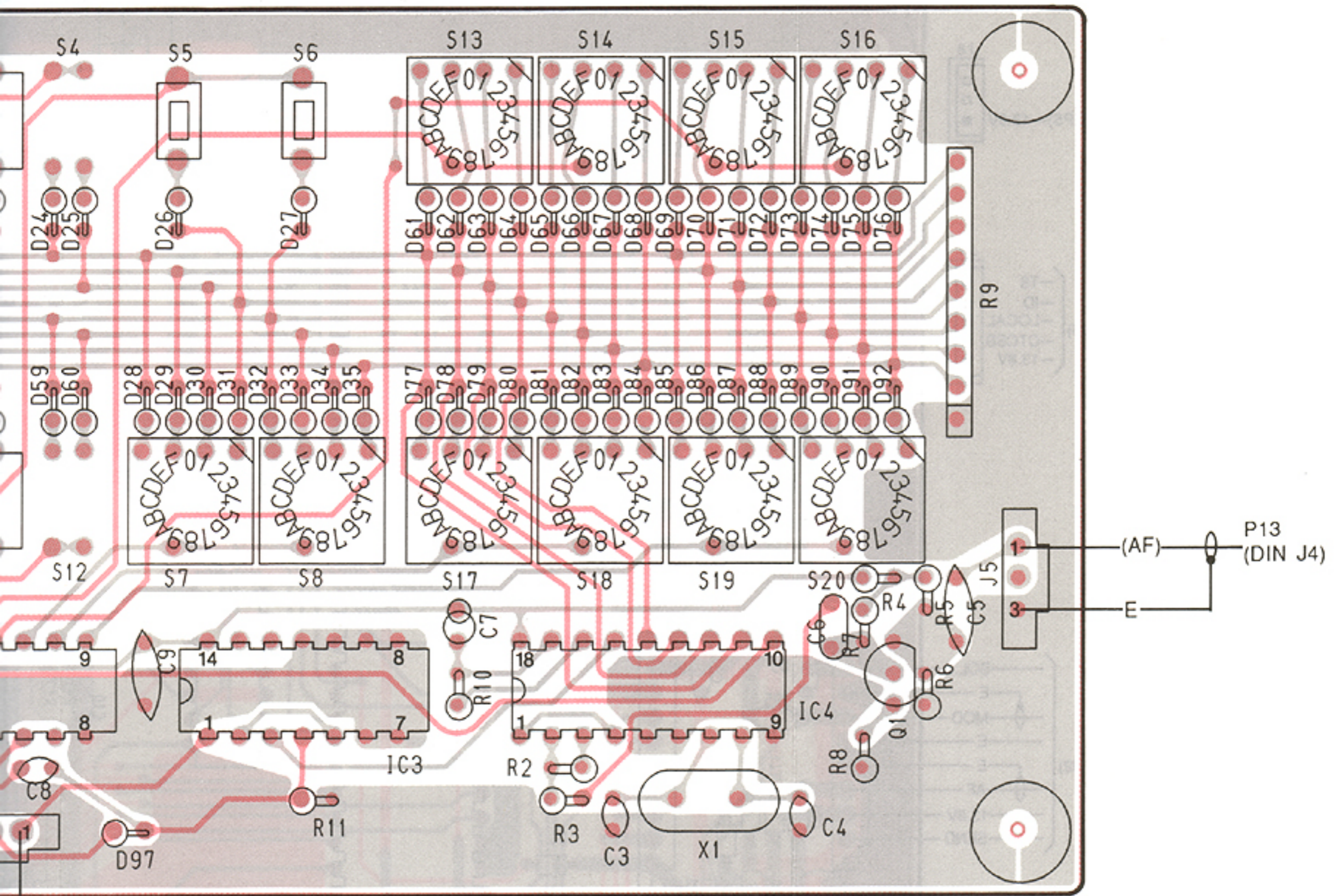

# 7-3 LOGIC UNIT

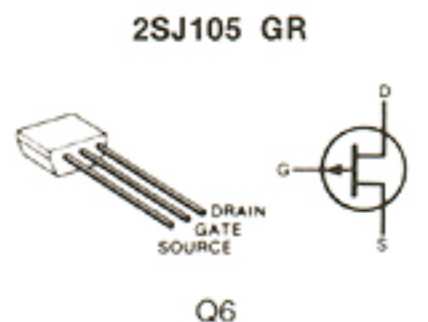
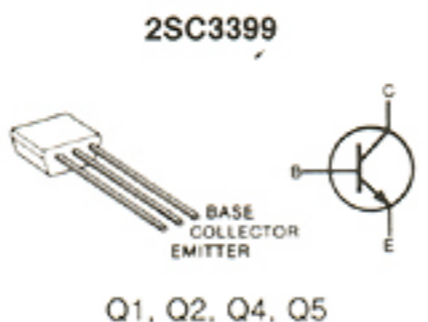
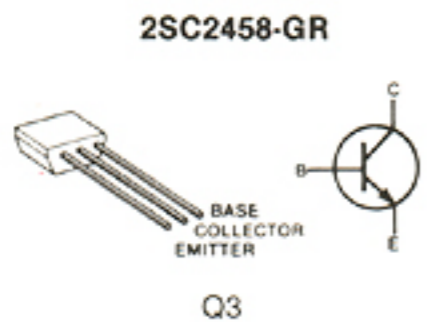
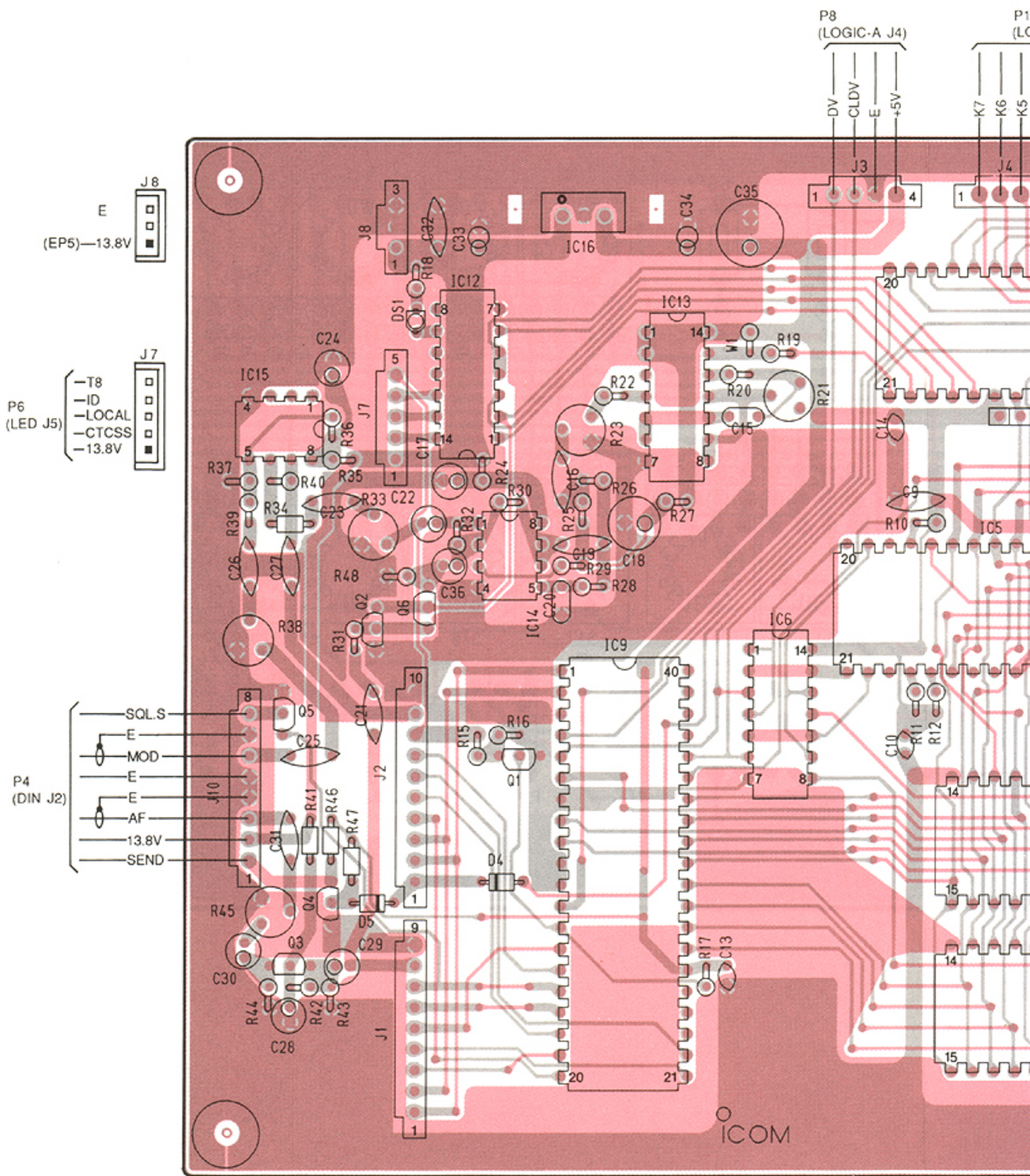

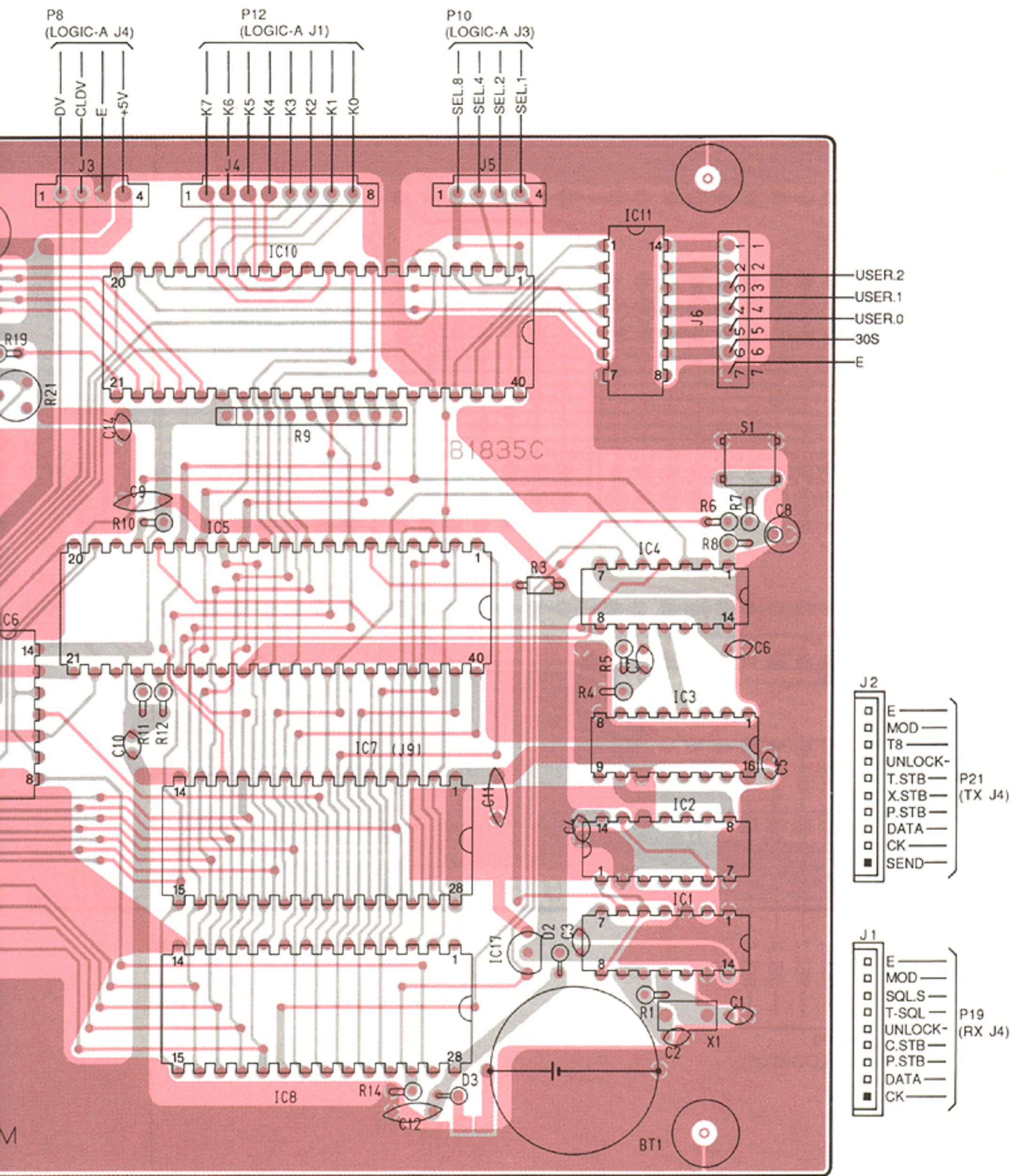

# 7-4 RX, R-VCO AND T-VCO UNITS

## • RX UNIT

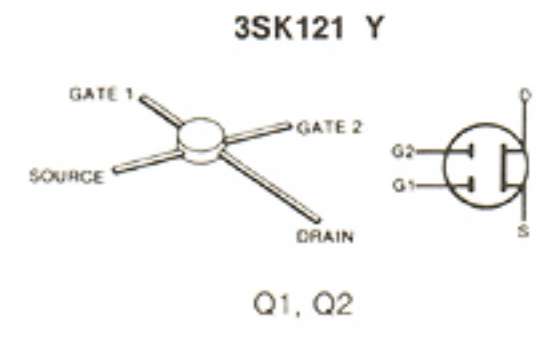
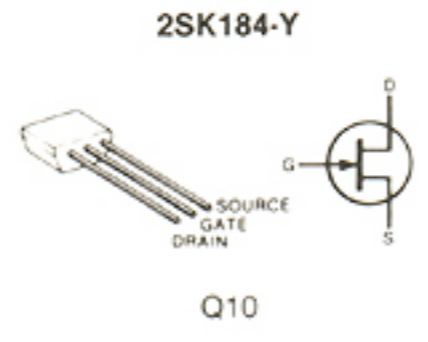
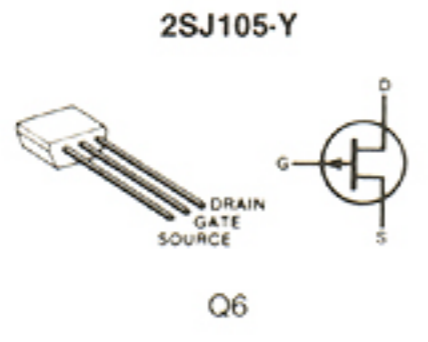
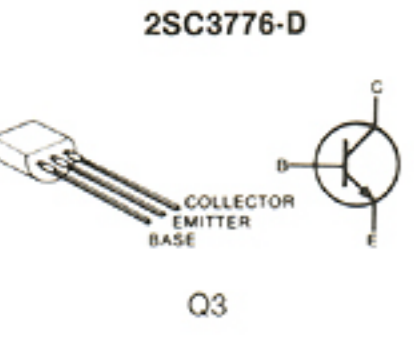
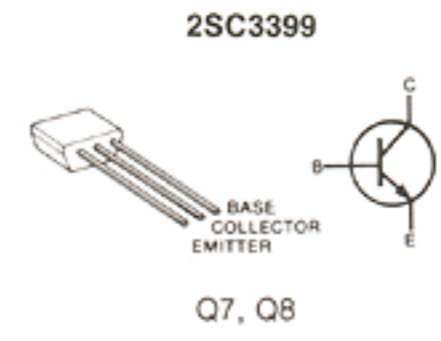
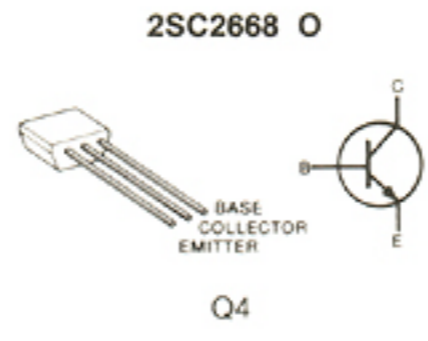
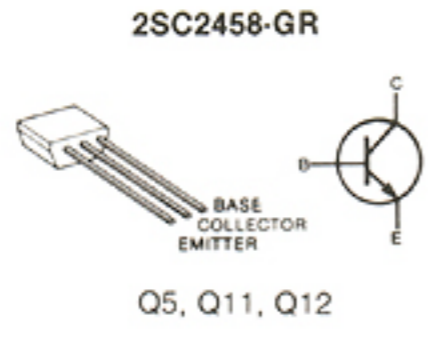
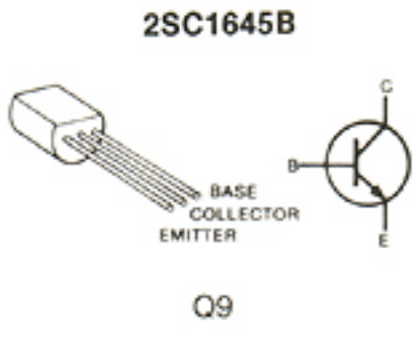
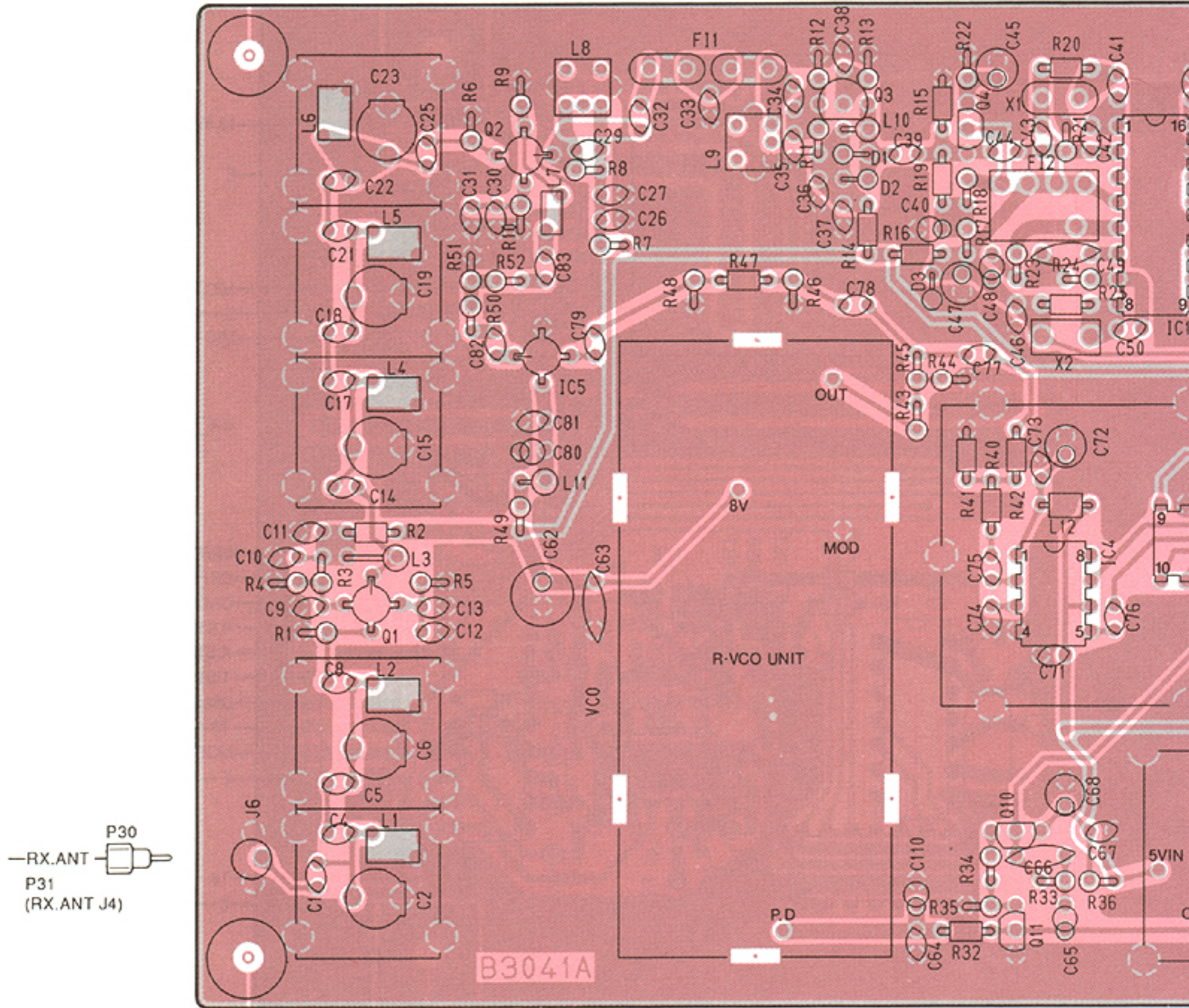



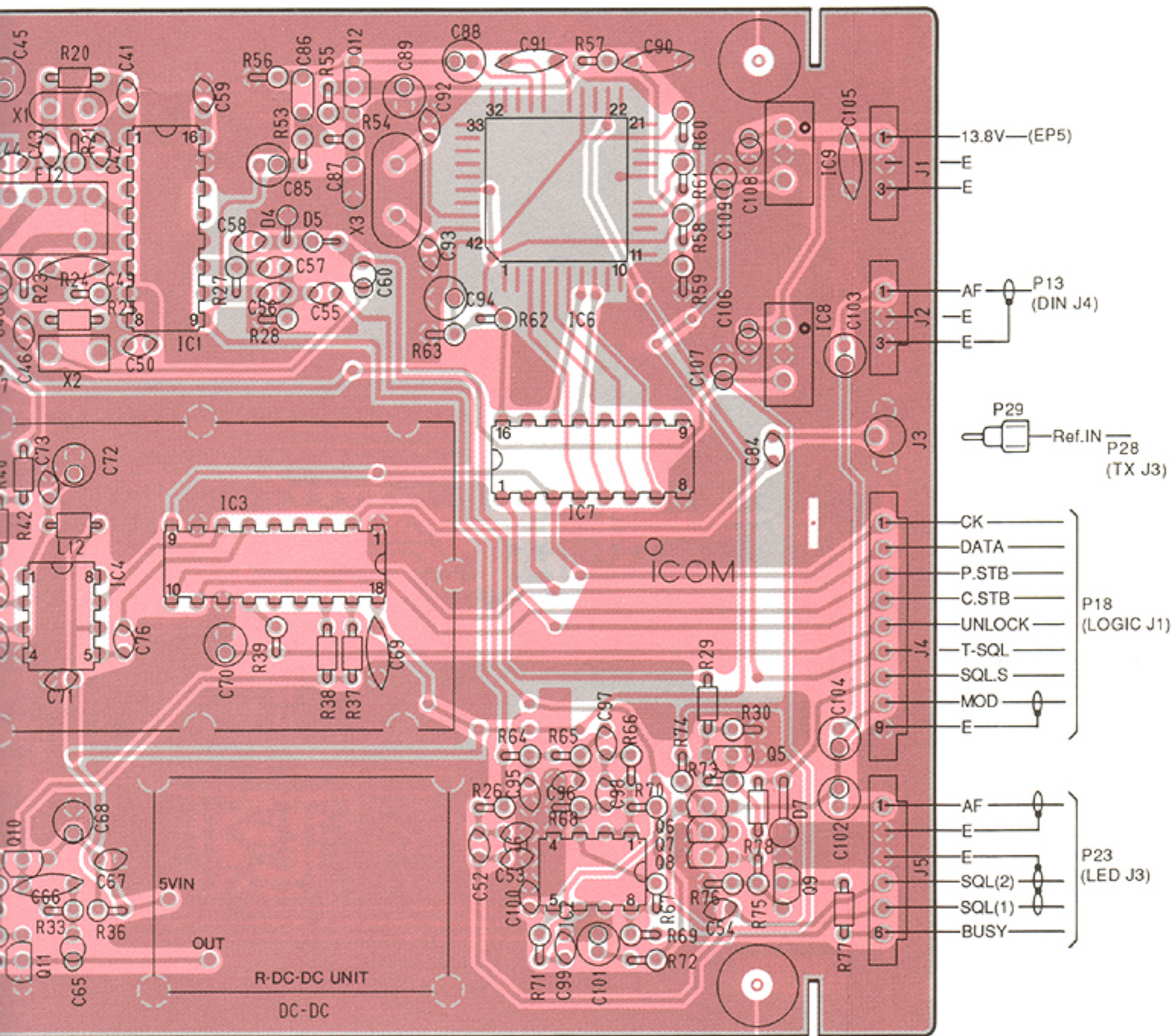

• R-VCO AND T-VCO UNITS

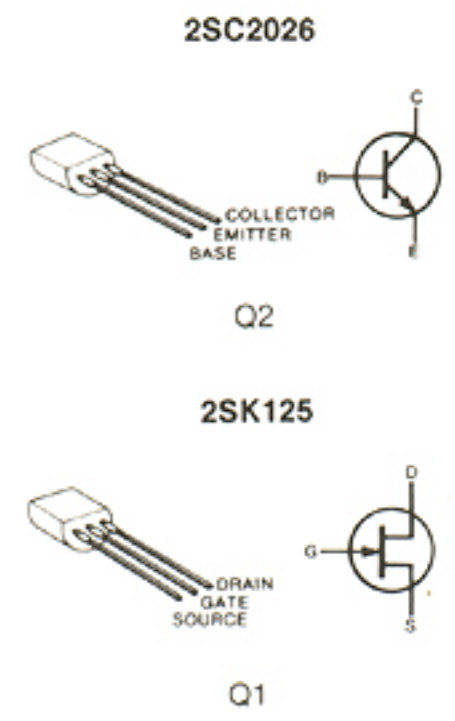
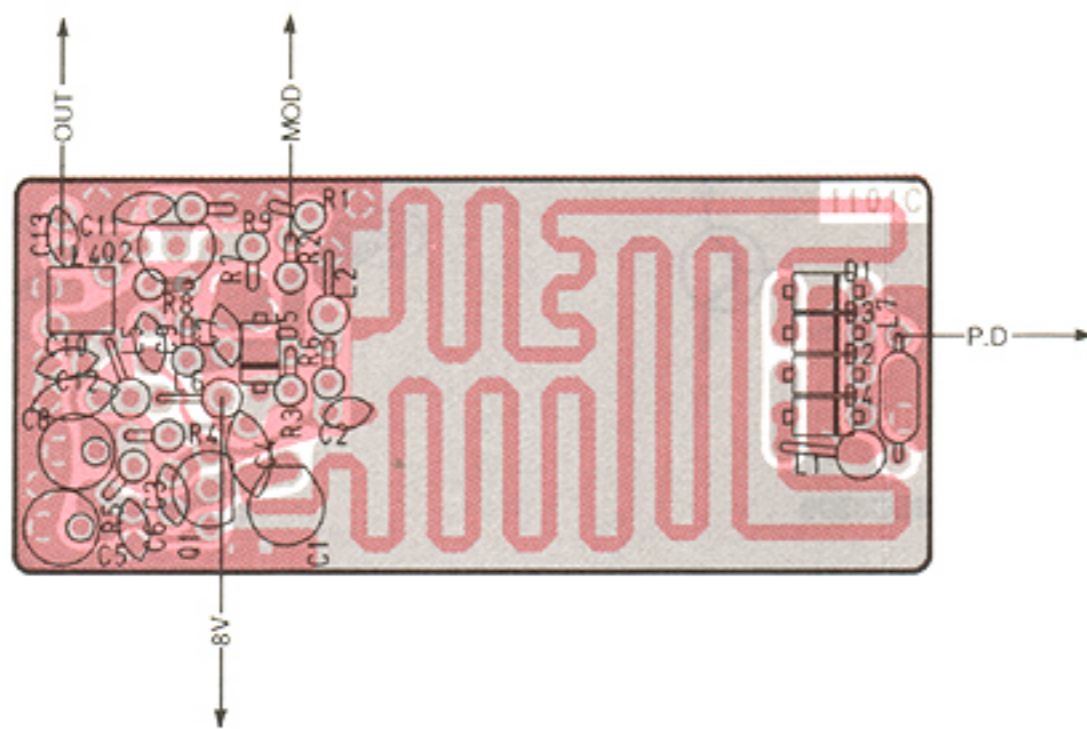

# 7-5 TX, R-DC-DC AND T-DC-DC UNITS

## • TX UNIT

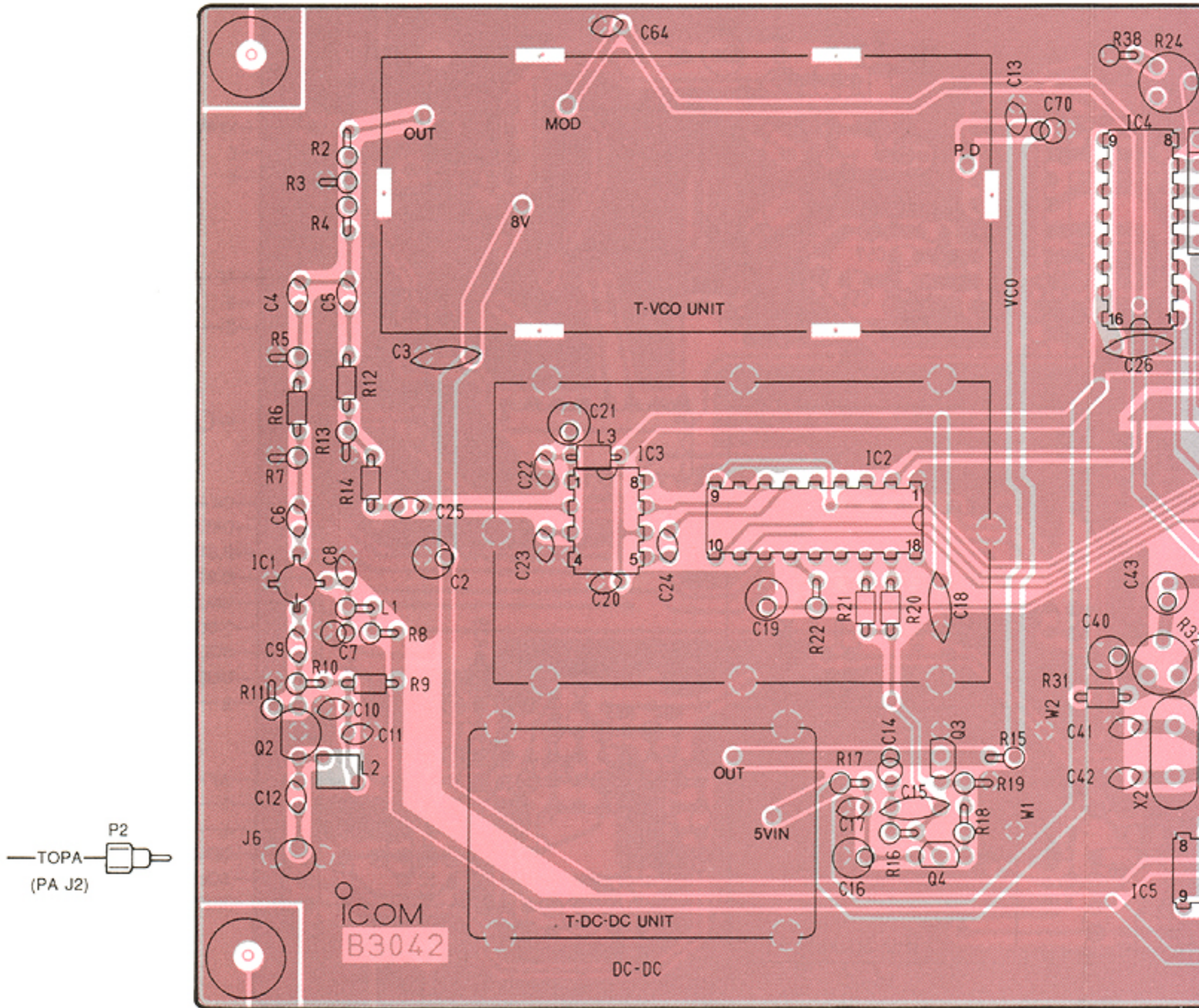

## • R-DC

2SB909M R



Q7

2SC2458-GR

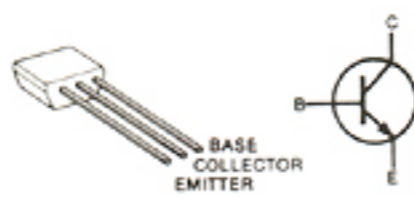

Q3

2SC2785 EL



Q5

2SC3355

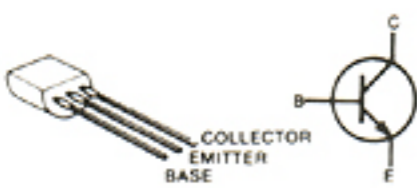

Q2

2SC3399

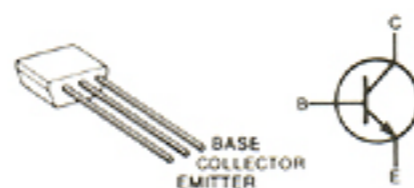

Q6

2SK184-Y

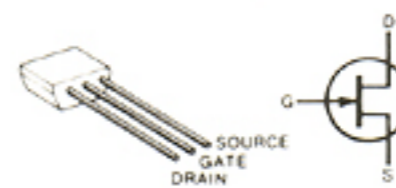

Q4

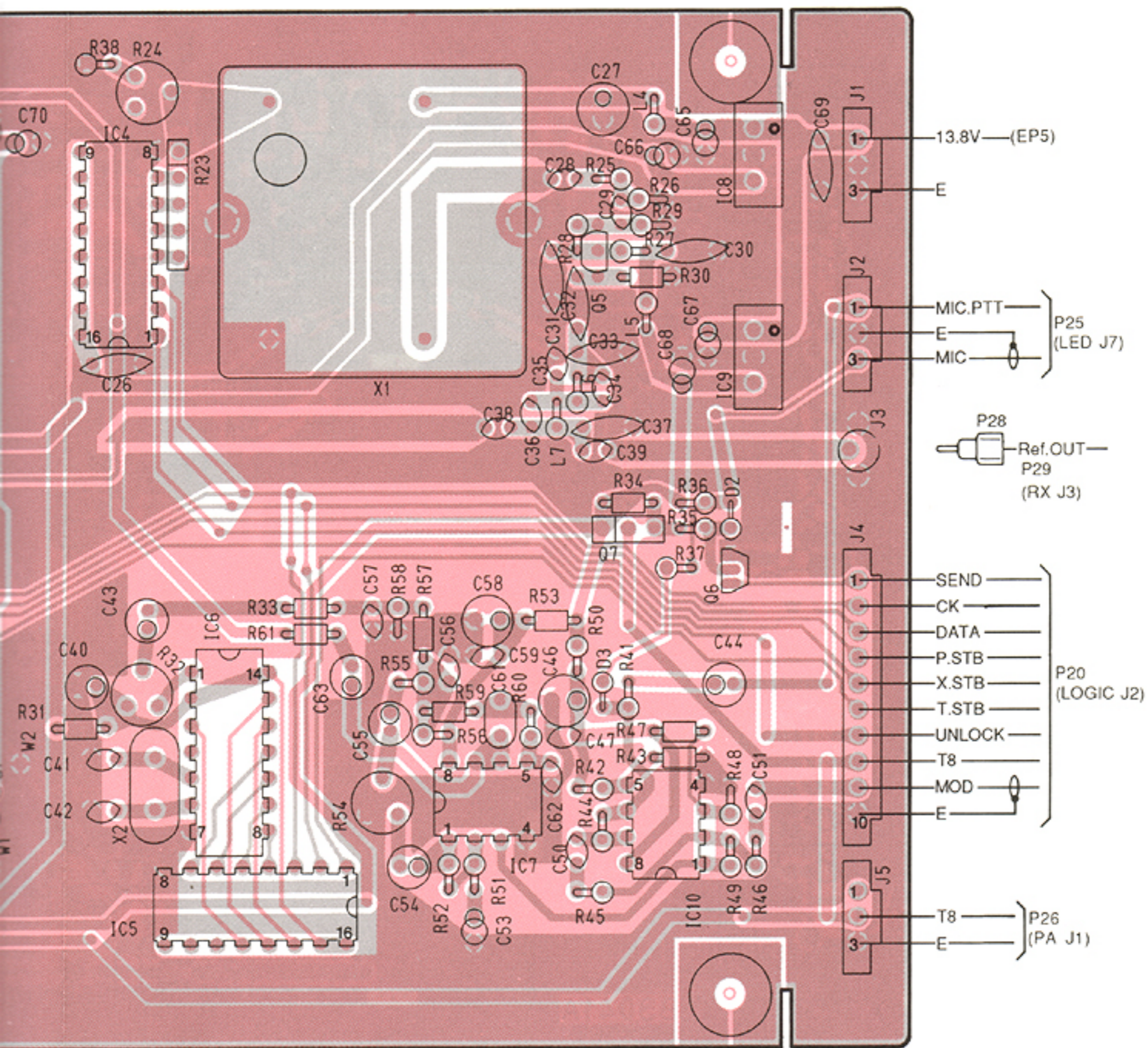

• R-DC-DC AND T-DC-DC UNITS

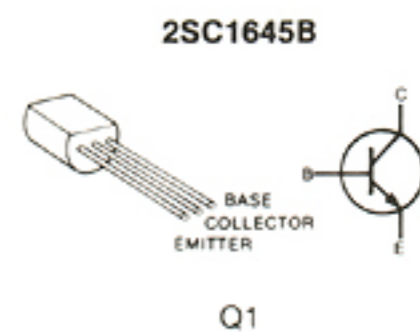
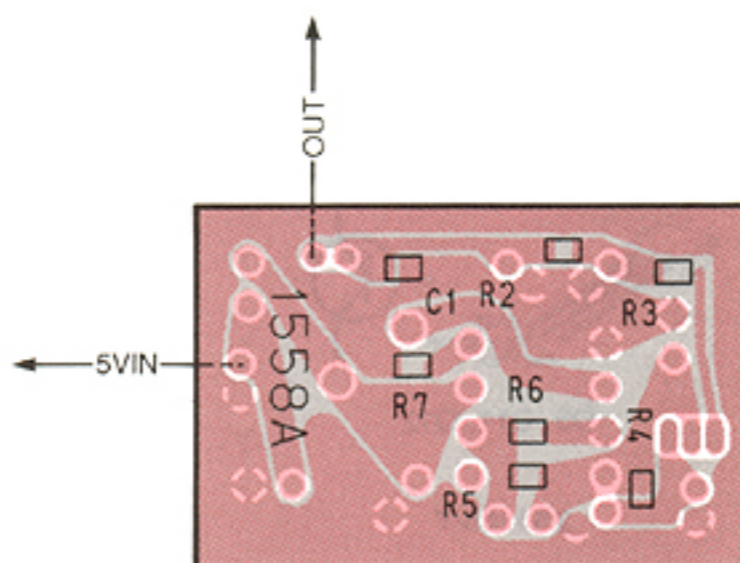
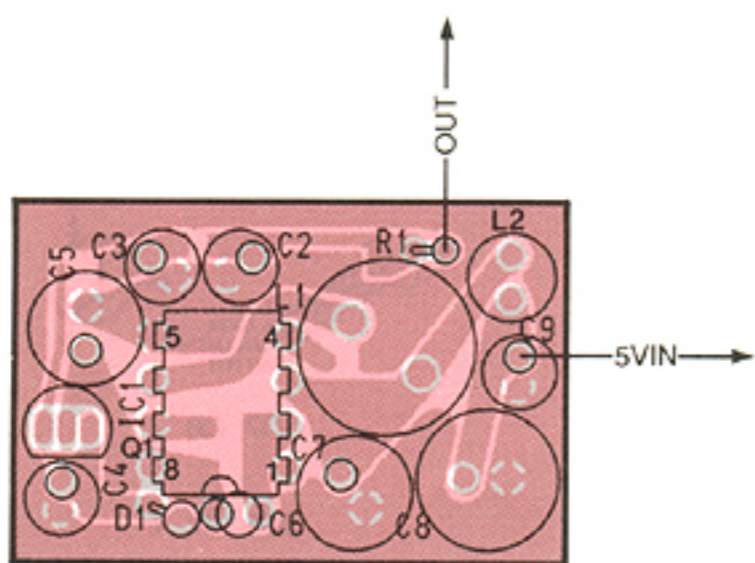

# 7-6 PA AND DIN UNITS

## • PA UNIT

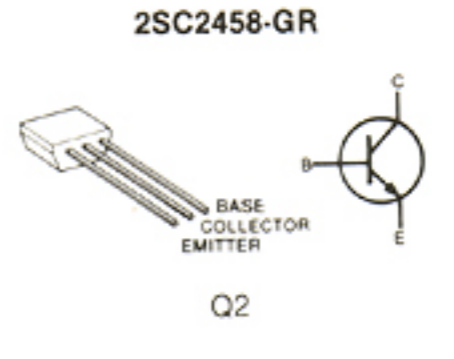
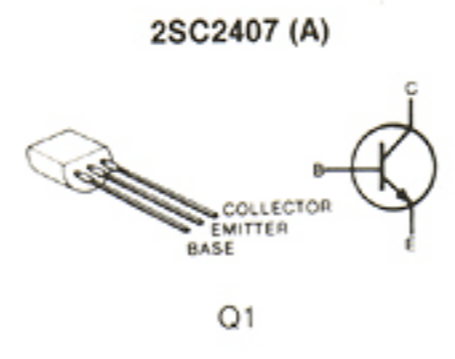
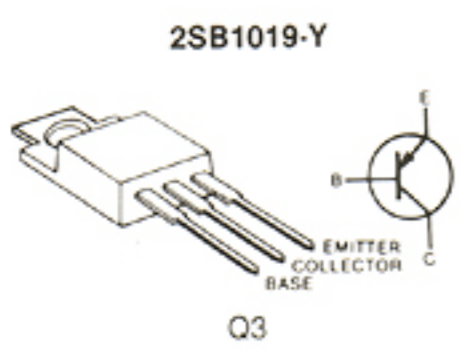
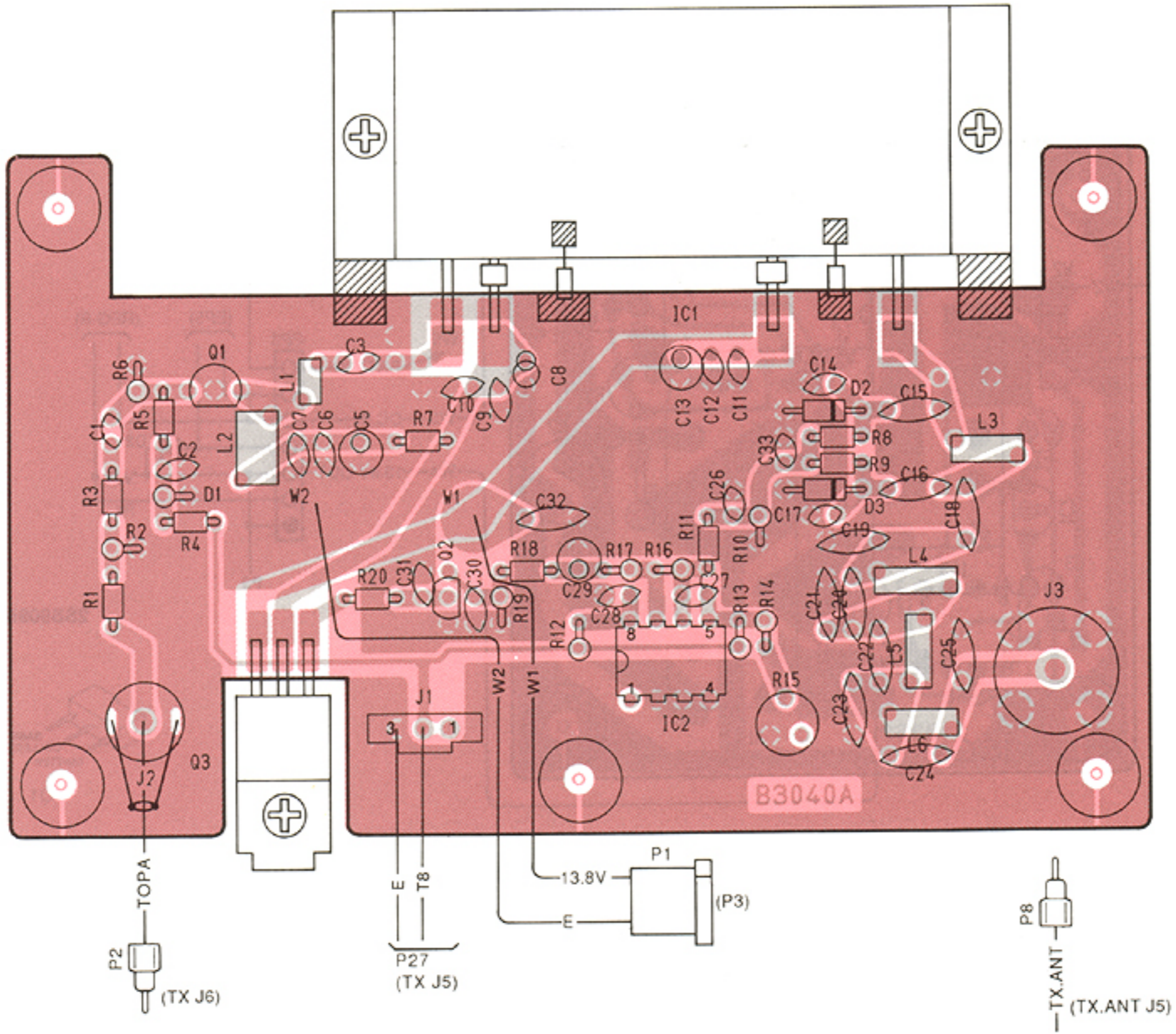

## • DIN UNIT

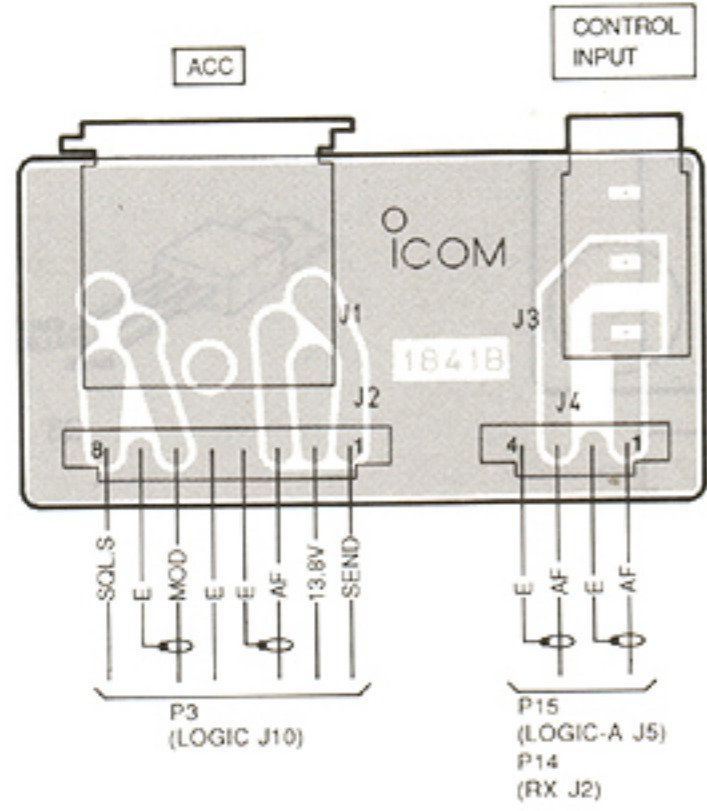

# 7-7 REG-A AND REG-B UNITS

## • REG-A UNIT

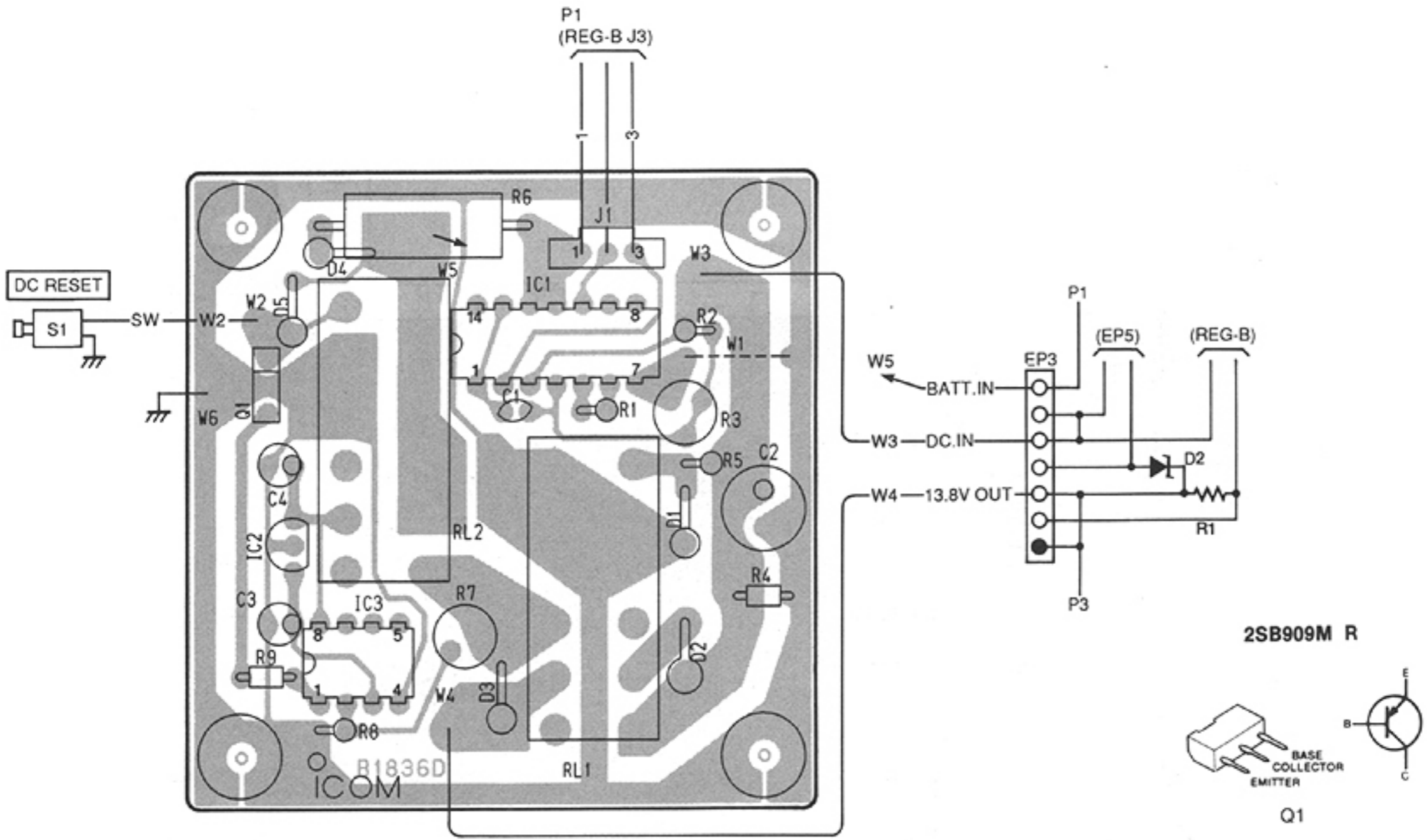

## • REG-B UNIT

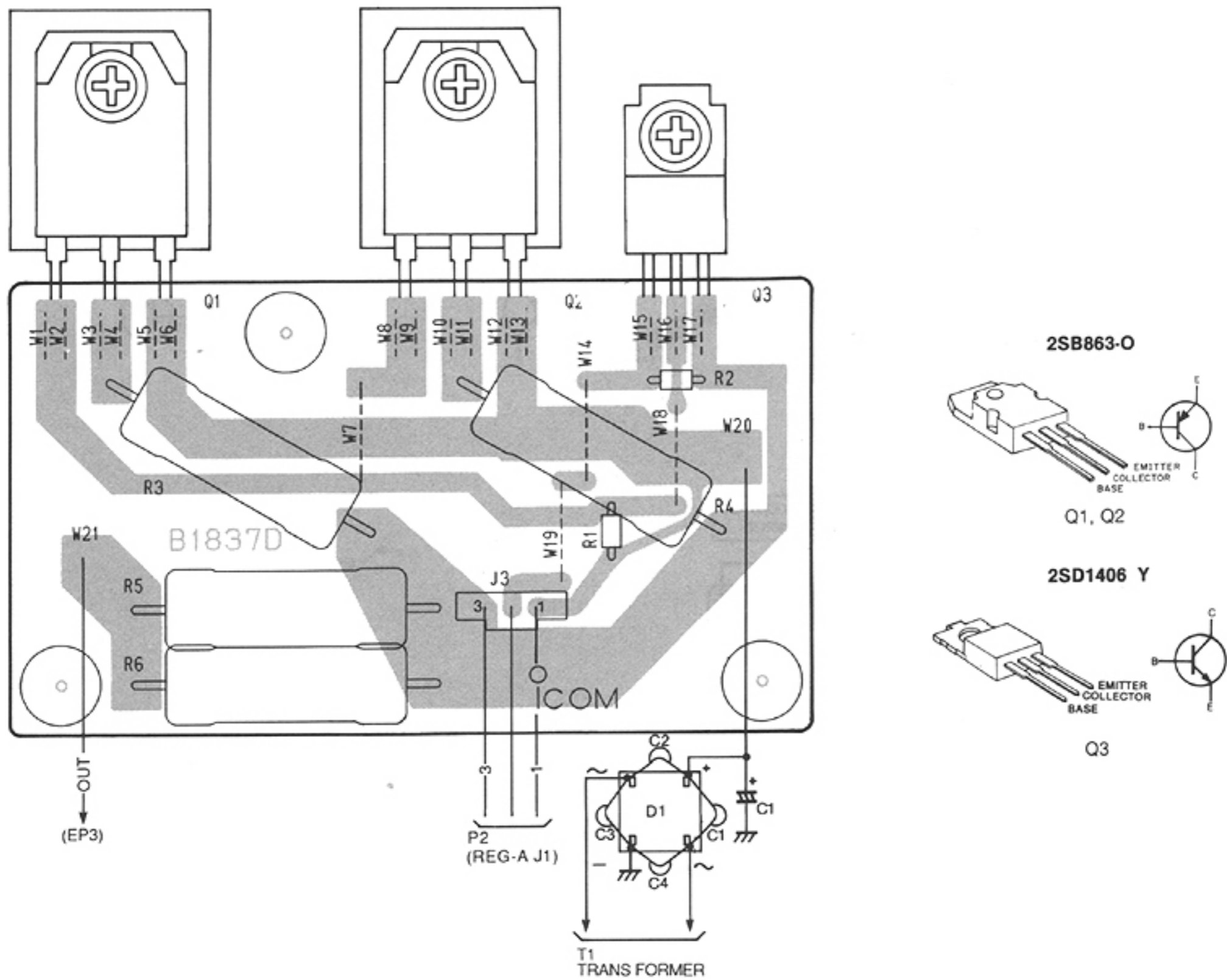

# SECTION 8 VOLTAGE DIAGRAM

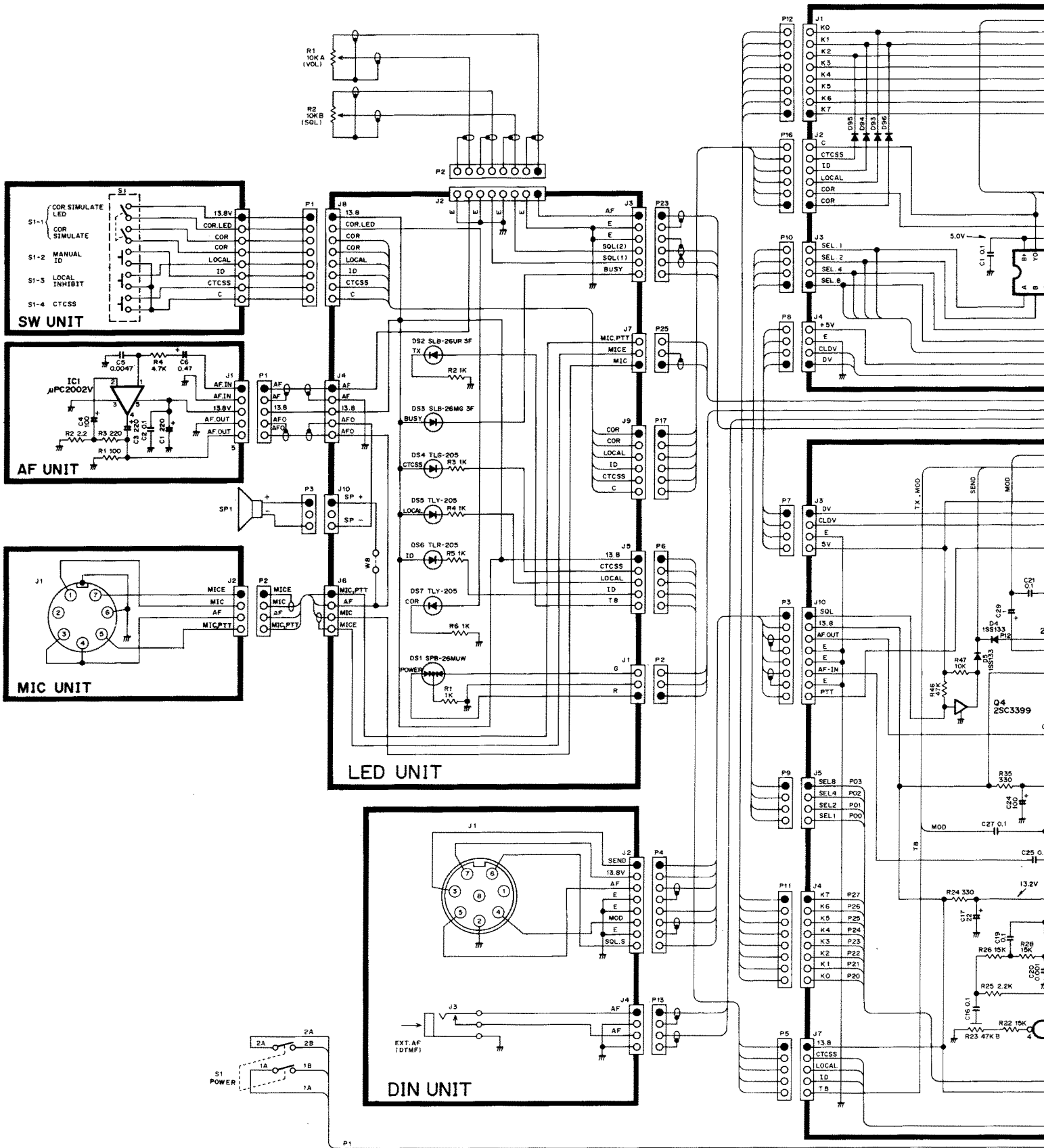

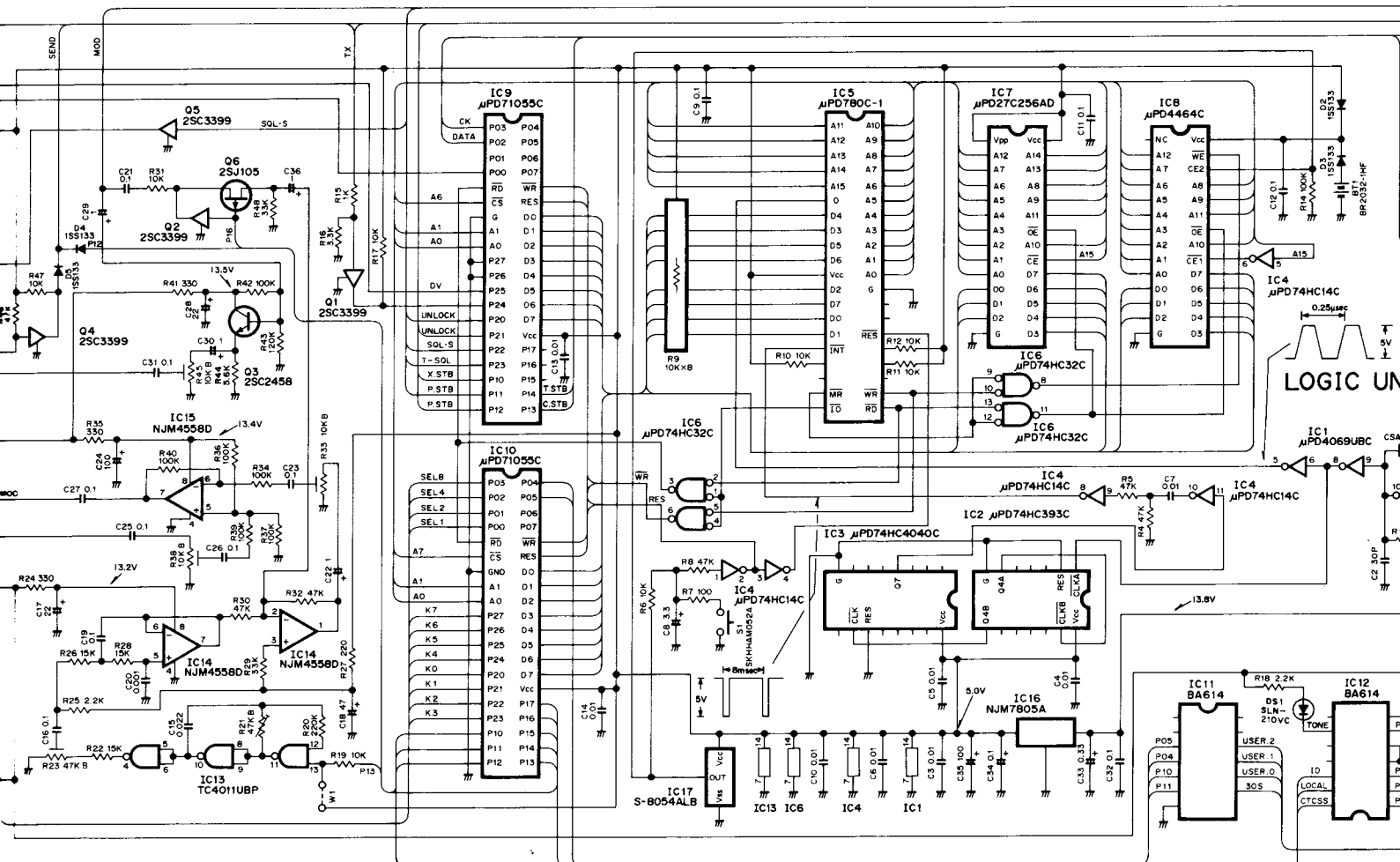
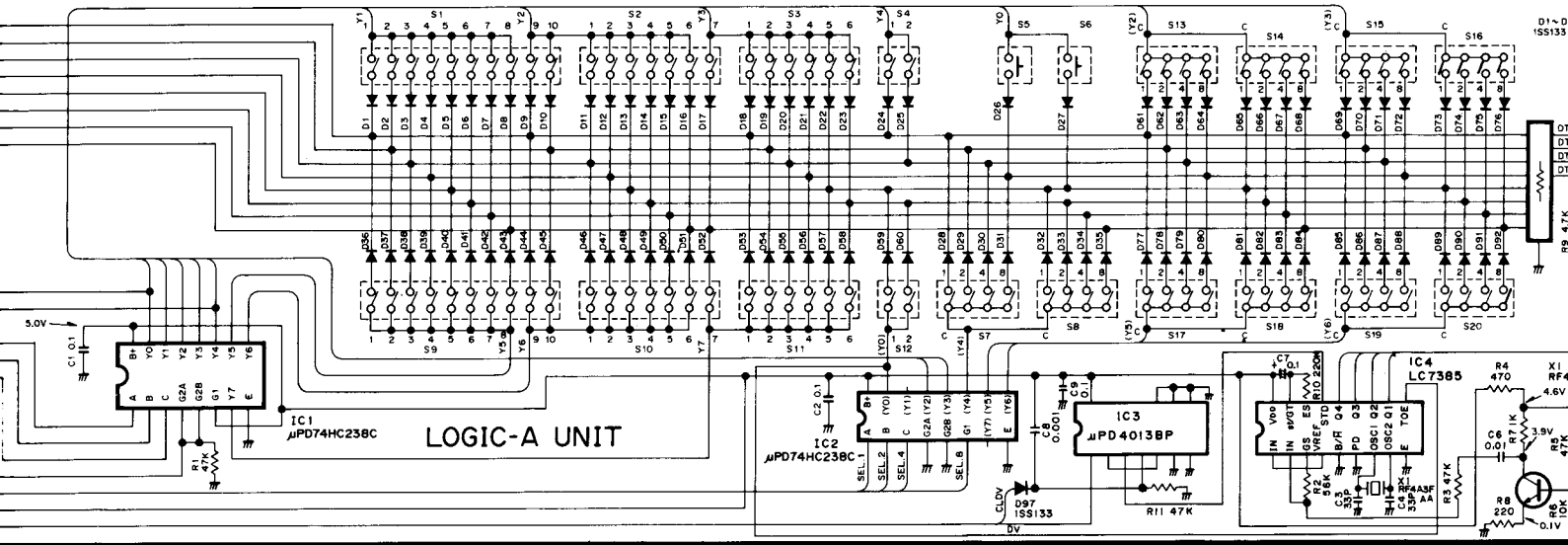

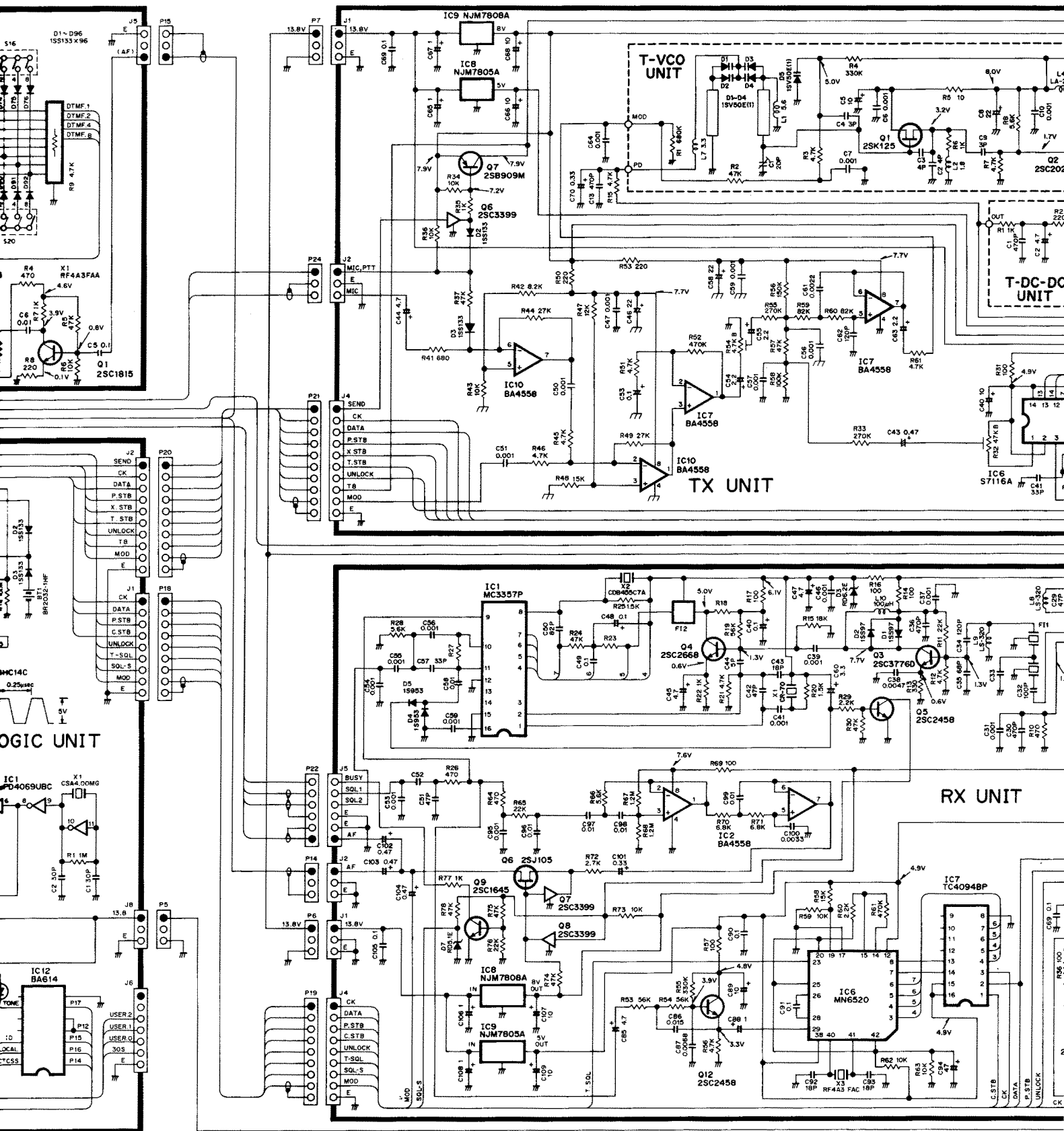

F11	2M1583	ITA(25W),EUR(25W),USA(25W)
	2M782	ITA(NARROW 25W),EUR(NARROW 25W),USA(NARROW 25W)
F12	CFW455E	ITA(25W),EUR(25W),USA(25W)
	CFW455HT	ITA(NARROW 25W),EUR(NARROW 25W),USA(NARROW 25W)

R18	1.5K	ITA(25W),EUR(25W)
	2.2K	ITA(NARROW 25W),EUR(NARROW 25W),USA(NARROW 25W)
R23	1.5K	ITA(25W),EUR(25W)
	2.2K	ITA(NARROW 25W),EUR(NARROW 25W),USA(NARROW 25W)



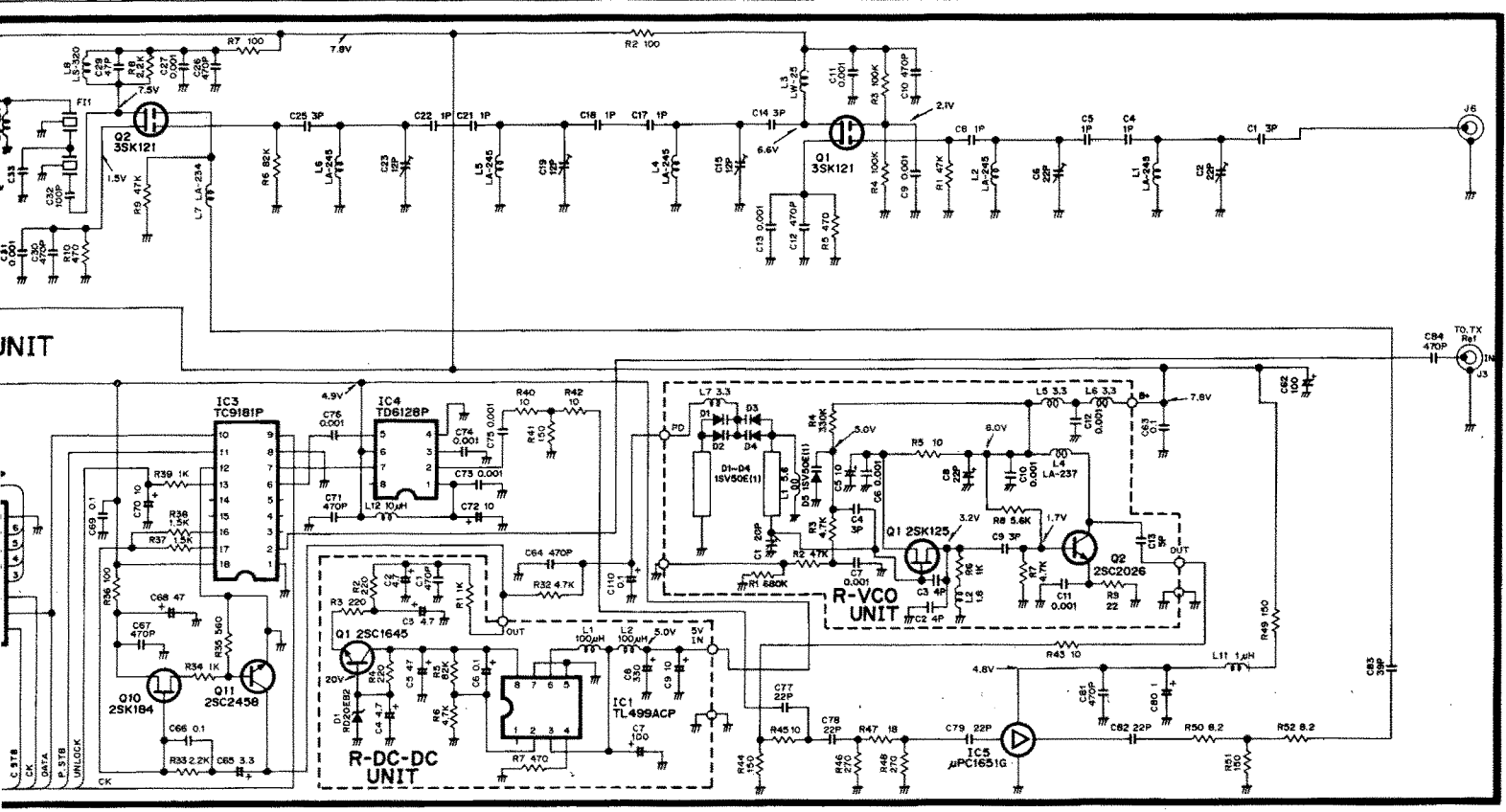
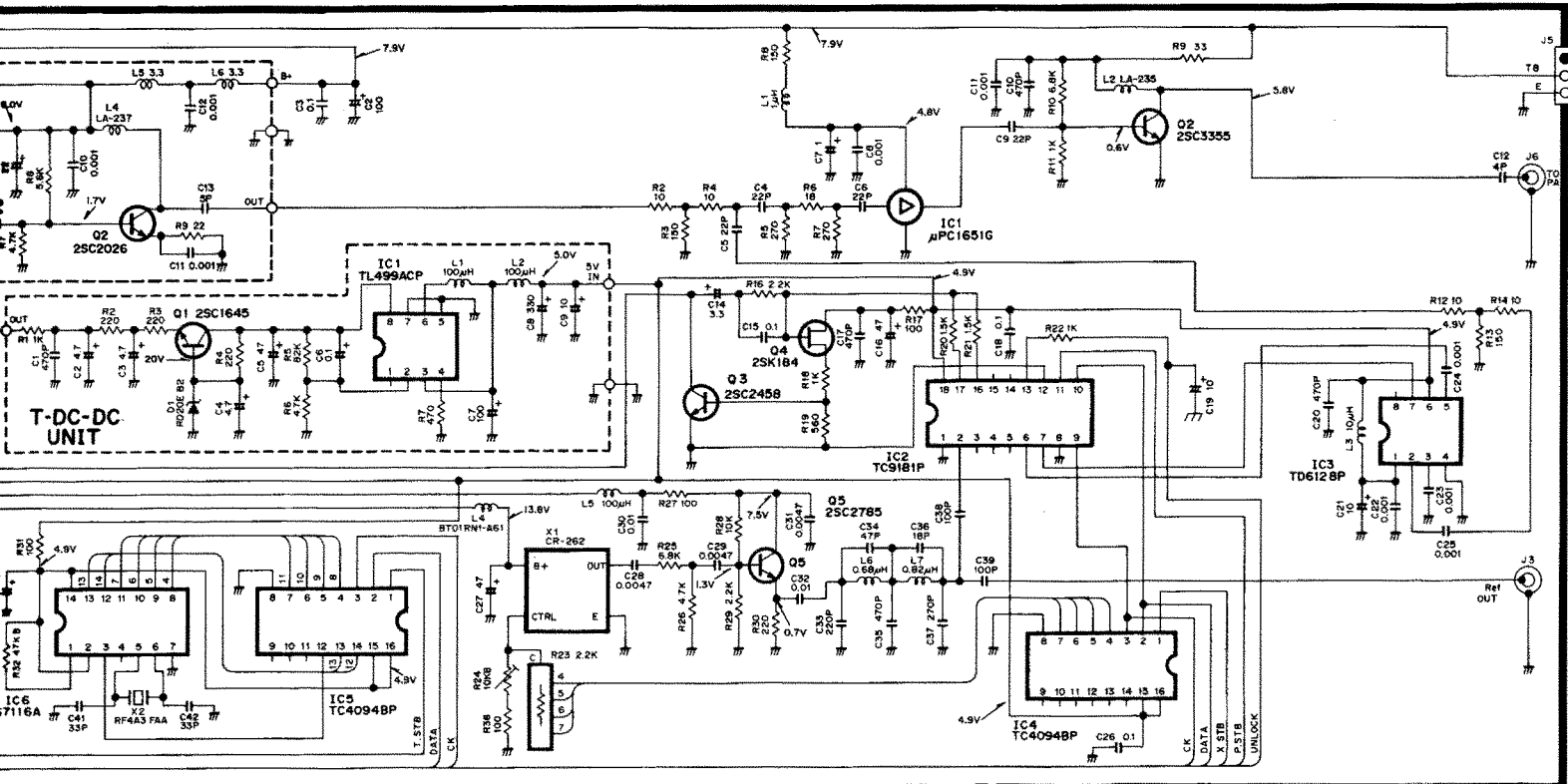

ITA(25W),EUR(25W),USA(25W)
ITA(NARROW 25W),EUR(NARROW 25W),USA(NARROW 25W)
ITA(25W),EUR(25W),USA(25W)
ITA(NARROW 25W),EUR(NARROW 25W),USA(NARROW 25W)

R27	330K	ITA(25W),EUR(25W),USA(25W)
	560K	ITA(NARROW 25W),EUR(NARROW 25W),USA(NARROW 25W)
C33	7P	ITA(25W),EUR(25W),USA(25W)
	15P	ITA(NARROW 25W),EUR(NARROW 25W),USA(NARROW 25W)

C52	0.0022	ITA(25W),EUR(25W),USA(25W)
	0.0068	ITA(NARROW 25W),EUR(NARROW 25W),USA(NARROW 25W)

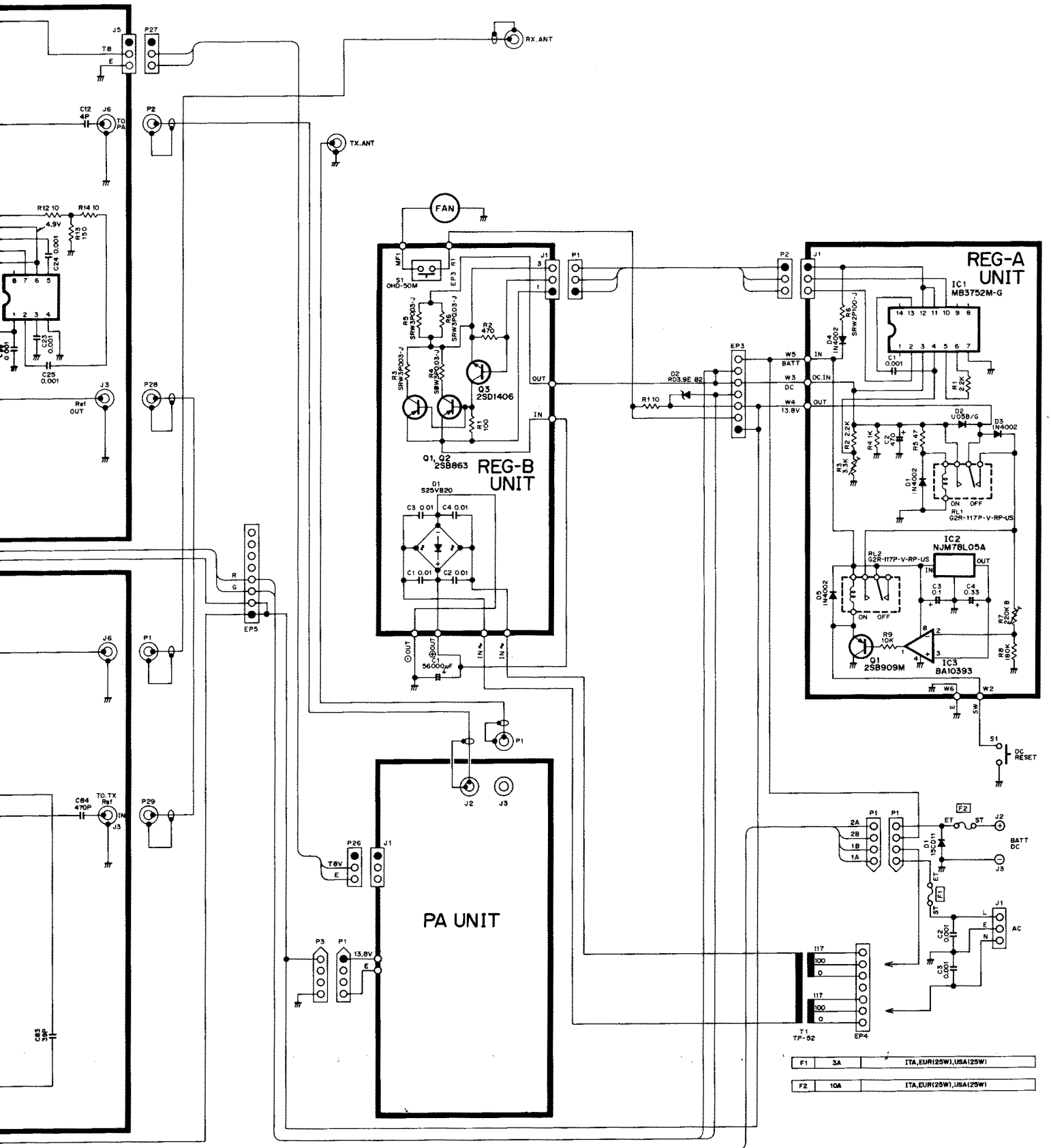

F1	3A	ITA, EUR(25W), USA(25W)
F2	10A	ITA, EUR(25W), USA(25W)

# PA UNIT

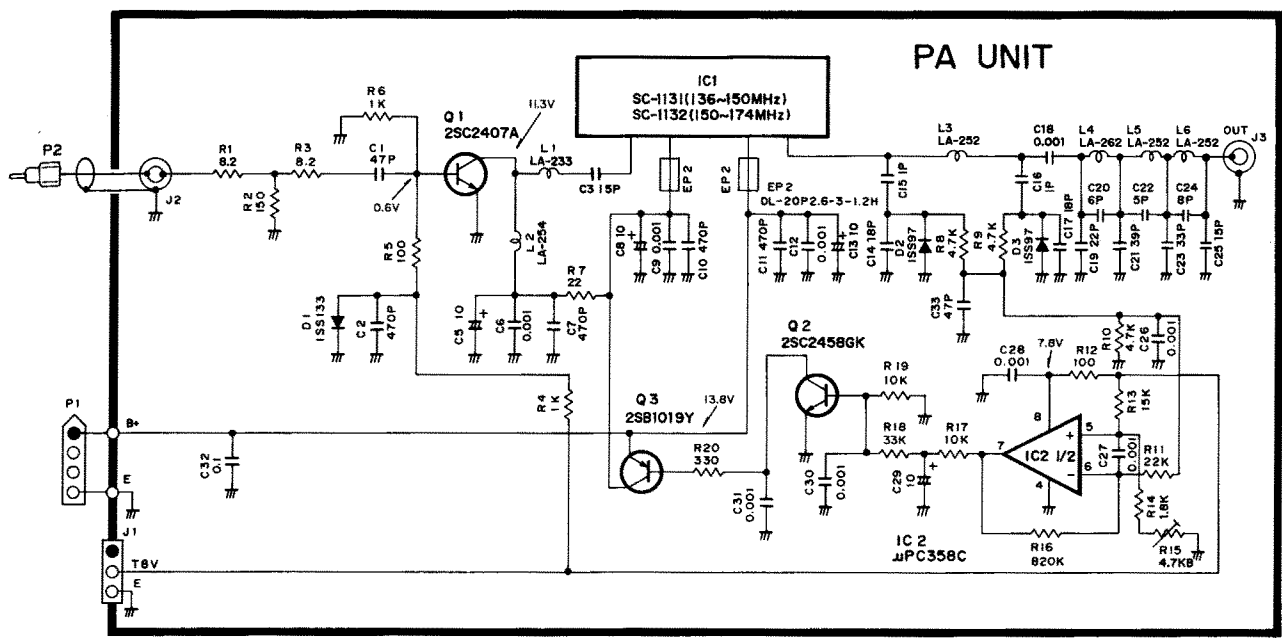

# SECTION 9 BLOCK DIAGRAM

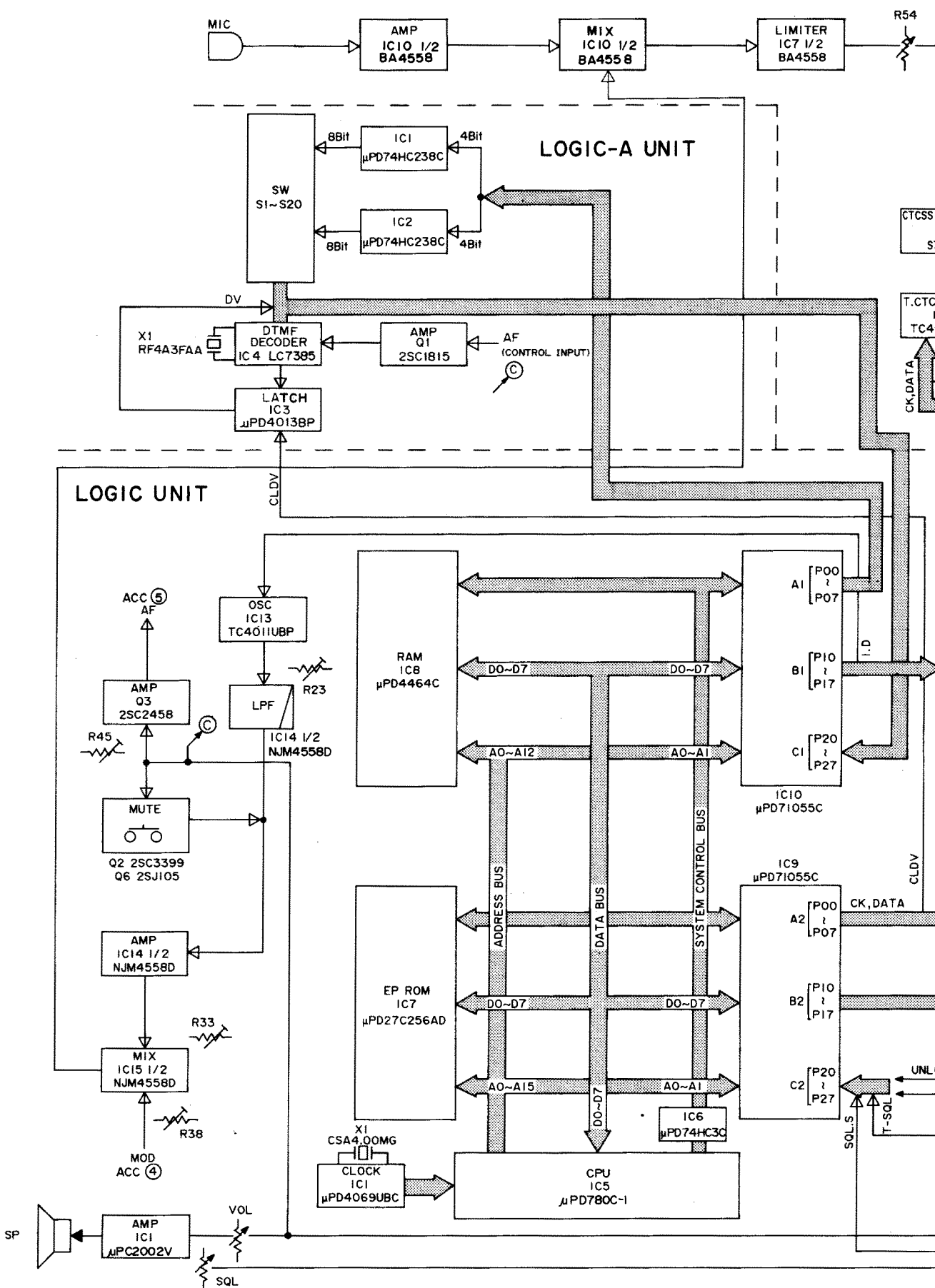

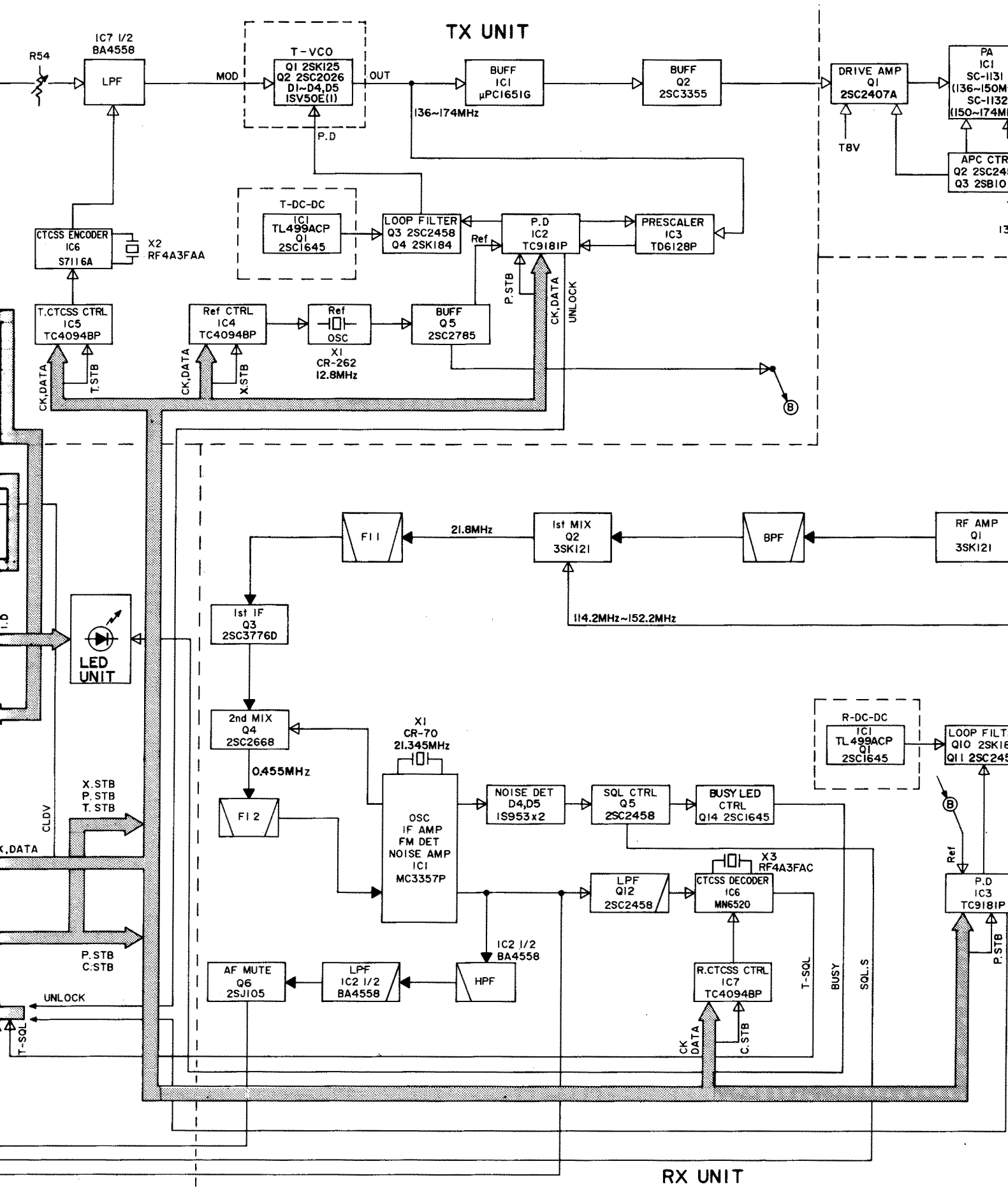

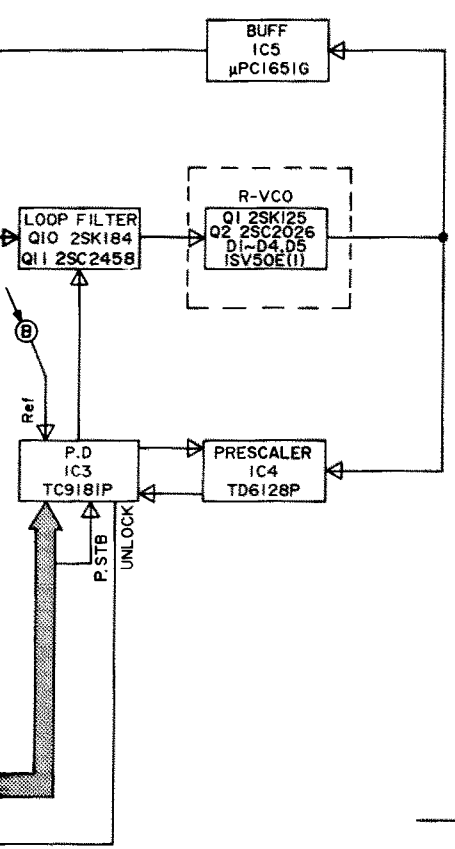
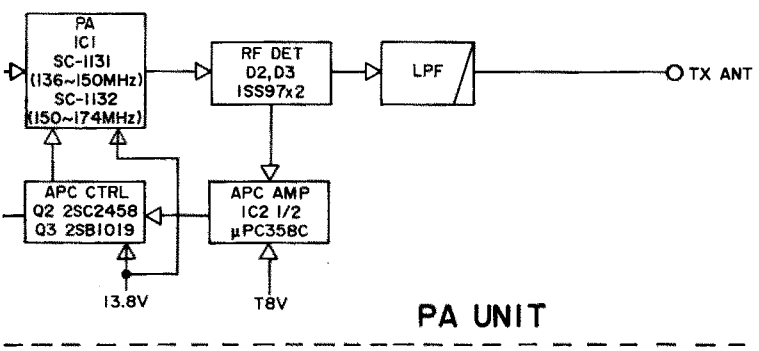

- RX
- ▷ TX
- ▷ RX/TX

## Icom Inc.

6-9-16, Kamihigashi, Hirano-ku, Osaka 547, Japan  
Phone: 06 793 5301  
Fax : 06 793 0013  
Telex : 05277822 ICOMTR J

### Icom America Inc.

<Corporate Headquarters>  
2380 116th Avenue N.E., Bellevue, WA 98004, U.S.A.  
Phone : (206) 454-8155  
Fax : (206) 454-1509  
Telex : 152210 ICOM AMER BVUE

<Customer Service>  
Phone : (206) 454-7619

<Regional Customer Service Centers>  
3150 Premier Drive, Suite 126, Irving, TX 75063, U.S.A.  
Phone : (214) 550-7525  
Fax : (214) 550-7423

1777 Phoenix Parkway, Suite 201, Atlanta, GA 30349, U.S.A.  
Phone : (404) 991-6166  
Fax : (404) 991-6327

### Icom Canada

A Division of Icom America Inc.  
3071 #5 Road, Unit 9, Richmond, B.C., V6X 2T4, Canada  
Phone : (604) 273-7400  
Fax : (604) 273-1900

### Icom (Europe) GmbH

Communication Equipment  
Himmelgeister Str. 100, 4000 Düsseldorf 1, W. Germany  
Phone : 0211 346047  
Fax : 0211 333639  
Telex : 8588082 ICOM D

### Icom (Australia) Pty. Ltd.

A.C.N. 006 092 575  
7 Duke Street, Windsor, Victoria, 3181, Australia  
Phone : 03 529 7582  
Fax : 03 529 8485  
Telex : AA 35521 ICOM AS

### Icom (UK) Ltd.

Unit 9, Sea St., Herne Bay, Kent, CT6 8LD, U.K.  
Phone : 0227 741741  
Fax : 0227 360155  
Telex : 965179 ICOM G

### Icom France S.a

120 Route de Revel, BP4063, 31029 Toulouse Cedex, France  
Phone : 61. 20. 31. 49  
Fax : 61. 34. 05. 91  
Telex : 521515 ICOM FRA

Count on us!

Icom Inc.

6-9-16, Kamihigashi, Hirano-ku, Osaka 547, Japan

A-5138H-S

Printed in Japan

Copyright © 1991 by Icom Inc.